

INSTALLATION

# ID ISC.ANT1710/690 Crystal Gate Excellence

Type A and B



## Note

© Copyright 2019 by  
FEIG ELECTRONIC GmbH  
Lange Strasse 4  
D-35781 Weilburg (Germany)  
Tel.: +49 6471 3109-0  
<http://www.feig.de>  
[identification-support@feig.de](mailto:identification-support@feig.de)

With the edition of this document, all previous editions become void. Indications made in this manual may be changed without previous notice.

Copying of this document and giving it to others and the use or communication of the contents thereof are forbidden without express authority. Offenders are liable to the payment of damages. All rights are reserved in the event of the grant of a patent or the registration of a utility model or design.

Composition of the information in this document has been done to the best of our knowledge. FEIG ELECTRONIC GmbH does not guarantee the correctness and completeness of the details given in this manual and may not be held liable for damages ensuing from incorrect or incomplete information. Since, despite all our efforts, errors may not be completely avoided, we are always grateful for your useful tips.

The instructions given in this manual are based on advantageous boundary conditions.

FEIG ELECTRONIC GmbH does not give any guarantee promise for perfect function in cross environments and does not give any guarantee for the functionality of the complete system which incorporates the subject of this document.

FEIG ELECTRONIC GmbH calls explicit attention that devices which are subject of this document are not designed with components and testing methods for a level of reliability suitable for use in or in connection with surgical implants or as critical components in any life support systems whose failure to perform can reasonably be expected to cause significant injury to human health. To avoid damage, injury or death the user or application designer must take reasonably prudent steps to protect against system failures.

FEIG ELECTRONIC GmbH assumes no responsibility for the use of any information contained in this document and makes no representation that they are free of patent infringement. FEIG ELECTRONIC GmbH does not convey any license under its patent rights nor the rights of others.

## General Information Regarding this Document

- The sign "↗" indicates extensions or changes of this manual compared with the former issue.
- If bits within one byte are filled with "–", these bit spaces are reserved for future extensions or for internal testing and manufacturing functions. These bit spaces must not be changed, as this may cause faulty operation of the reader.
- The following figure formats are used:
  - 0...9: for decimal figures,
  - 0x00...0xFF for hexadecimal figures,
  - b0...1 for binary figures.
- The hexadecimal value in brackets "[ ]" marks a control byte (command).

## Contents

<b>1</b>	<b>Safety Instructions</b>	<b>7</b>
<b>2</b>	<b>Revision History of Documentation</b>	<b>8</b>
<b>3</b>	<b>Instruction on Transportation and Shipping of the Antenna</b>	<b>9</b>
<b>4</b>	<b>Maintenance and Cleaning</b>	<b>10</b>
<b>5</b>	<b>Performance Features of the ID ISC.ANT1710/690 Antennas</b>	<b>11</b>
<b>5.1</b>	<b>Scope of Delivery</b> .....	<b>11</b>
5.1.1	Antenna ID ISC.ANT1710/690 Crystal Gate Excellence Type A .....	11
5.1.2	Antenna ID ISC.ANT1710/690 Crystal Gate Excellence Type B .....	11
<b>5.2</b>	<b>Performance Features of the People Counter ID ISC.ANT.GPC</b> .....	<b>12</b>
<b>5.3</b>	<b>Available Antenna Types</b> .....	<b>14</b>
<b>6</b>	<b>Installation and Wiring</b>	<b>15</b>
<b>6.1</b>	<b>Mounting Preparation</b> .....	<b>15</b>
<b>6.2</b>	<b>Installing the Antenna</b> .....	<b>17</b>
6.2.1	Dimensions of the Antenna .....	17
6.2.2	Drilling the Mounting Holes .....	18
6.2.3	Installing the Antenna Base and Antenna Body .....	20
<b>7</b>	<b>Typical Antenna Configuration (Gate Antenna with two Antennas)</b>	<b>22</b>
<b>7.1</b>	<b>Project Notes Antenna</b> .....	<b>22</b>
<b>7.2</b>	<b>Project Notes People Counter (GPC)</b> .....	<b>25</b>
<b>7.3</b>	<b>Gate Configuration and Setup Using Antennas</b> .....	<b>27</b>
7.3.1	Required Components .....	27
7.3.2	Configuration of a Gate Antenna with Multiplexer .....	29
7.3.3	Setting the Multiplexer .....	34
7.3.4	Setting the Antenna Tuner .....	35
7.3.5	Interface Connections .....	36
7.3.6	Reader Configuration with Multiplexer .....	37

IDENTIFICATION	Contents
7.3.7 Tuning the Gate Antenna .....	40
<b>7.4 Testing the Gate Antenna .....</b>	<b>41</b>
7.4.1 Checking the Noise Level .....	41
7.4.2 Reading a Serial Number .....	43
7.4.3 Testing the Performance .....	44
<b>7.5 Setting the Alarm Indicators (Alarm Buzzer and Alarm LED lights) .....</b>	<b>46</b>
7.5.1 Setting the Alarm Buzzer .....	46
7.5.2 Setting the LEDs .....	47
7.5.3 Reader Setting for Alarm Indicators .....	48
7.5.4 Programming a Transponder with the AFI Byte .....	50
<b>7.6 Activating a Reader Automatic Mode .....</b>	<b>51</b>
<b>7.7 Automatic Bus Addressing .....</b>	<b>52</b>
<hr/>	
<b>8 Installation Gate People Counter ID ISC.ANT.GPC in Antenna No.4 Type B .....</b>	<b>53</b>
<b>8.1 Installation ID ISC.ANT.GPC-E2 .....</b>	<b>53</b>
<b>8.2 Installation and Connections .....</b>	<b>55</b>
<b>8.3 Configuration and Test .....</b>	<b>61</b>
8.3.1 Connecting Several People Counters .....	61
8.3.2 Configuration and Test in ISO Host Mode or Buffered Read Mode .....	62
8.3.3 Configuration and Test in Notification Mode .....	65
8.3.4 Using the Trigger Function of the Gate People Counter .....	67
8.3.5 Using the Direction Detection of Transponders with the Gate People Counter .....	69
8.3.6 Detection Area of the Direction Mode .....	70
<hr/>	
<b>9 Reader Configuration in Accordance with National RF Regulations .....</b>	<b>71</b>
<hr/>	
<b>10 Technical Data .....</b>	<b>73</b>
<b>10.1 Antenna ID ISC.ANT1710/690 Type A and B Crystal Gate Excellence .....</b>	<b>73</b>
<b>10.2 People Counter ID ISC.ANT.GPC and ID ISC.ANT.GPC-E2 .....</b>	<b>75</b>
<b>10.3 Power Supply ID ISC.NET24V-B .....</b>	<b>76</b>
<hr/>	
<b>11 Approvals .....</b>	<b>77</b>
<b>11.1 Europe (CE) .....</b>	<b>77</b>
11.1.1 Antenna ID ISC.ANT1710/690 Crystal Gate Excellence .....	77

<b>IDENTIFICATION</b>	<b>Contents</b>
11.1.2 People Counter ID ISC.ANT.GPC.....	77
<b>11.2 USA (FCC) and Canada (IC) .....</b>	<b>78</b>
11.2.1 Antenna ID ISC.ANT1710/690-Crystal Gate Excellence.....	78
11.2.2 People Counter ID ISC.ANT.GPC.....	79
<b>11.3 USA and Canada (UL).....</b>	<b>80</b>
<hr/>	
<b>Annex</b>	<b>81</b>
<hr/>	
<b>Annex A: Terminal Assignment “Terminal Board” .....</b>	<b>81</b>
<b>Annex B: Internal Wiring .....</b>	<b>82</b>

## 1 Safety Instructions

- ▶ The device may only be used for the intended purpose designed by the manufacturer.
- ▶ The operation manual should be conveniently kept available at all times for each user.
- ▶ Unauthorized changes and the use of spare parts and additional devices which have not been sold or recommended by the manufacturer may cause fire, electric shocks or injuries. Such unauthorized measures shall exclude any liability by the manufacturer.
- ▶ The liability-prescriptions of the manufacturer in the issue valid at the time of purchase are valid for the device. The manufacturer shall not be held legally responsible for inaccuracies, errors, or omissions in the manual or automatically set parameters for a device or for an incorrect application of a device.
- ▶ Repairs may only be executed by the manufacturer.
- ▶ Installation, operation and maintenance procedures should only be carried out by qualified personnel.
- ▶ Use of the device and its installation must be in accordance with national legal requirements and local electrical codes.
- ▶ When working on devices the valid safety regulations must be observed.
- ▶ Please observe that some parts of the device may heat severely.
- ▶ Before touching the device, the power supply must always be interrupted. Make sure that the device is without voltage by measuring. The fading of an operation control (LED) is no indicator for an interrupted power supply or the device being out of voltage!
- ▶ For installation and dismantling you should wear suitable safety gloves, because parts of the antenna housing could be sharp-edged.
- ▶ Special advice for carriers of cardiac pacemakers:  
Although this device doesn't exceed the valid limits for electromagnetic fields you should keep a minimum distance of 25 cm between the device or the antenna and your cardiac pacemaker.

### **CAUTION!**

- ***The antenna tuner and the antenna conductor carry voltages up to 1000V!***
- ***Do not look directly into the alarm LED light. There is a danger of injury of the eyes!***

### **NOTE:**

***The Antenna is not water proof and should not be exposed to rain or humidity.  
Under extreme circumstances water could seep into the antenna and damage the electronic circuits.***

**IDENTIFICATION**

## 2 Revision History of Documentation

Revision	Date	Description
0	15.04.2019	Initial version
1	25.10.2019	Error correction
2	04.02.2020	Error correction, Pipe diameter added
3	17.03.2020	Error correction, Setting the sensitivity of the radar module changed



### 3 Instruction on Transportation and Shipping of the Antenna

The packaging of the antennas has been designed to transport antennas vertically standing on a pallet to the site of installation.

① **NOTE:**

***The antenna must be transported vertically on the base side of the pallet. Transport or storage in the wrong orientation can cause damage to the antenna.***

In case a vertically positioned transport is not possible, the antenna can be transported lying on the narrow side. A transporting lying on the flat side of the packaging can cause damage to the device.

The pallet has to be adapted to the size and the number of antennas. In no case shall the packaging stand out of the range. An additional protection of the edges of the pallet is recommended.

The packaging must never become wet. When transporting overseas by ship or plane, the packaging must be protected from moisture at all times.

Temperatures above or below the specified temperature range may damage the antenna.

Any mechanical stress on the packaging is not permitted. Any stacking of the packaging may cause damage to the packaging below.

Even after the unpacking of the antenna the face of the antenna plate must always be transported and stored vertically. Horizontal transport of an antenna may deform the antenna plate.



## 4 Maintenance and Cleaning

The antenna ID ISC.ANT1710/690 is a design product with high quality surfaces, and should always be handled with care. The antenna is designed to work reliably and flawlessly for years without special maintenance.

To improve the durability and the appearance, please follow the instructions below:

- Keep the antenna clean and take care not to scratch the antenna. Also regularly apply specific antistatic products for acrylic surfaces.
- Remove dust and other impurities regularly with a soft cloth and a solution of water with a little dishwashing liquid.
- Keep the antenna dry. Avoid all kinds of during operation and storage. Precipitation, moisture and liquids contain minerals that corrode electronic circuits and damage transparent plastic parts.
- Protect the antenna from high temperatures. Mount the antenna away from radiators and other heat sources. Operation in direct sunlight can cause extremely high temperatures and fading of the surface.
- Avoid storing or operating the antenna in dirty or wet locations. The surfaces or electronic components may be damaged.
- Handle the device with care. Shocks may damage internal circuit boards.
- Do not attempt to open the antenna during operation or outside maintenance periods. Non-professional management may cause damage to the device.

If a device is not working properly, please contact your authorized representative.

① **NOTE:**

- ***Under no circumstances should water get into the antenna base. Water damages the electronics in the antenna!***
- ***The use of alcohol, spirit, thinners, glass cleaners or other harsh cleaning liquids is prohibited and will damage the acrylic plate.***

## 5 Performance Features of the ID ISC.ANT1710/690 Antennas

The ID ISC.ANT1710/690-A Crystal Gate Excellence antenna is a version with integrated Dynamic Antenna Tuning Board ID ISC.DAT, Long Range Reader ID ISC.LRM2500-BB, 8-times Multiplexer Module ID ISC.ANT.MUX.M8, additional alarm LED and alarm buzzer.

Additionally, a people counter and a radar detector are already integrated into the antenna ID ISC.ANT1710/690-A Crystal Gate Excellence.

The ID ISC.ANT1710/690-B Crystal Gate Excellence antenna is a version only with integrated Dynamic Antenna Tuning Board ID ISC.DAT and alarm LED.

Up to

- two antennas with reader and multiplexer as a single gate,
- three to four antennas with reader and multiplexer as a double gate or triple gate

can be operated.

Depending on the antenna configuration, reading one, two or all three tag orientations of the smart tags and various aisle widths (gate widths) are possible.

The ID ISC.ANT1710/690-A/-B Crystal Gate Excellence is a device with 2 antennas with tuner and has been optimized as transmit and receive antenna for the ID ISC.LRM2500 reader. However, it is also possible to operate it with other readers at a transmission frequency of 13.56 MHz and an output impedance of 50  $\Omega$ . The read ranges and tuning procedures given in this document may vary.

The antennas comprise the electrical antenna conductor, the housing, the ID ISC.DAT *Dynamic Antenna Tuner* and the connection cables. The antennas are factory tuned to an impedance of 50  $\Omega$  in a magnetically neutral environment at a distance of 100 cm. When installing under different environmental conditions, the antenna can be recalibrated using the PC software "DATuningTool". After tuning, the antennas will retain their settings as long as the environmental conditions remain unchanged.

The antennas can be used for both product and person detection. They are intended for indoor use only.

### 5.1 Scope of Delivery

#### 5.1.1 Antenna ID ISC.ANT1710/690 Crystal Gate Excellence Type A

- Antenna ID ISC.ANT1710/900-A including 2 dynamic antenna tuner
- Long Range Reader Module ID ISC.LRM2500-BB
- 8 Channel Multiplexer Module ID ISC.ANT.MUX.M8
- Power Supply ID ISC.Net24V-B 100-240V/ 24V
- People Counter ID ISC.ANT.GPC

#### 5.1.2 Antenna ID ISC.ANT1710/690 Crystal Gate Excellence Type B

- Antenna ID ISC.ANT1710/690-B including 2 dynamic antenna tuner
- Data cable 2,5m long, for LED's and People Counter
- Antenna connector cable 8m long

## 5.2 Performance Features of the People Counter ID ISC.ANT.GPC

The product ID ISC.ANT.GPC, short form “Gate People Counter” or “GPC”, is intended for installation in the gate antenna ID ISC.ANT1710/690.

A Gate People Counter consists of a People Counter board (PC) and a radar detector. The ID ISC.ANT.GPC-E2 Extension Radar Detector is used to extend the People Counter to a second gate aisle.

The people counter has two counters per aisle. The values of the incoming and outgoing persons are registered separately.

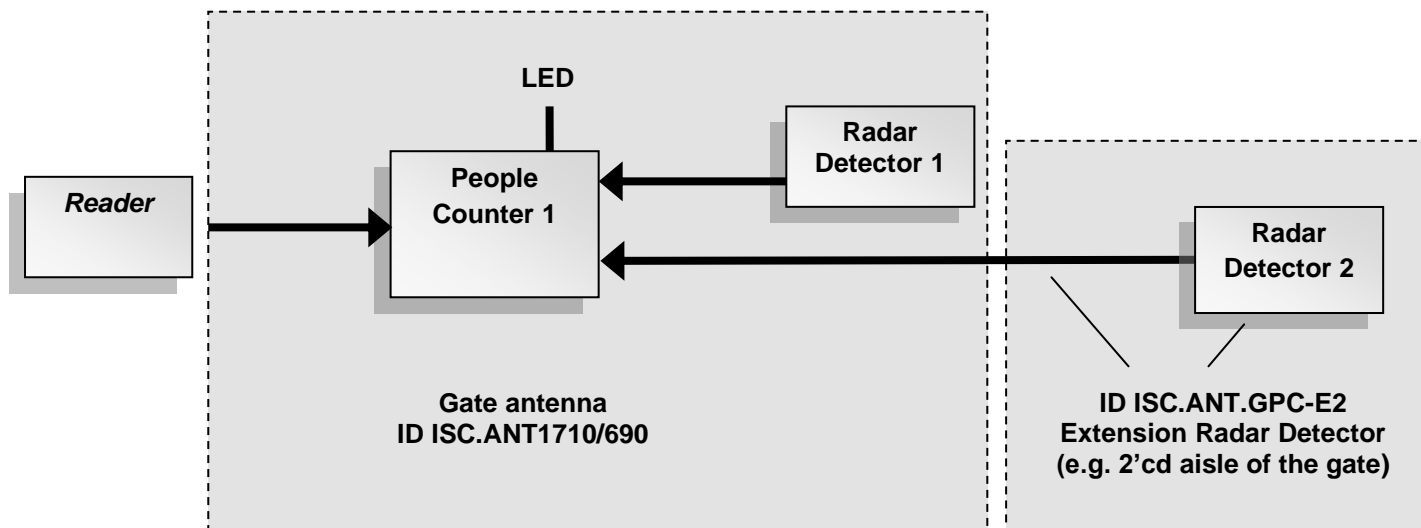

Fig. 1: Gate People Counter Structure (2-3 antennas, 1-2 gate aisles)

A change of the counter values is stored in the EEPROM of the people counter board. By sending the command [0x78] Set People Counter the values can be set/reset to the desired value.

The counter values are sent to the LCD screen every 5 seconds.

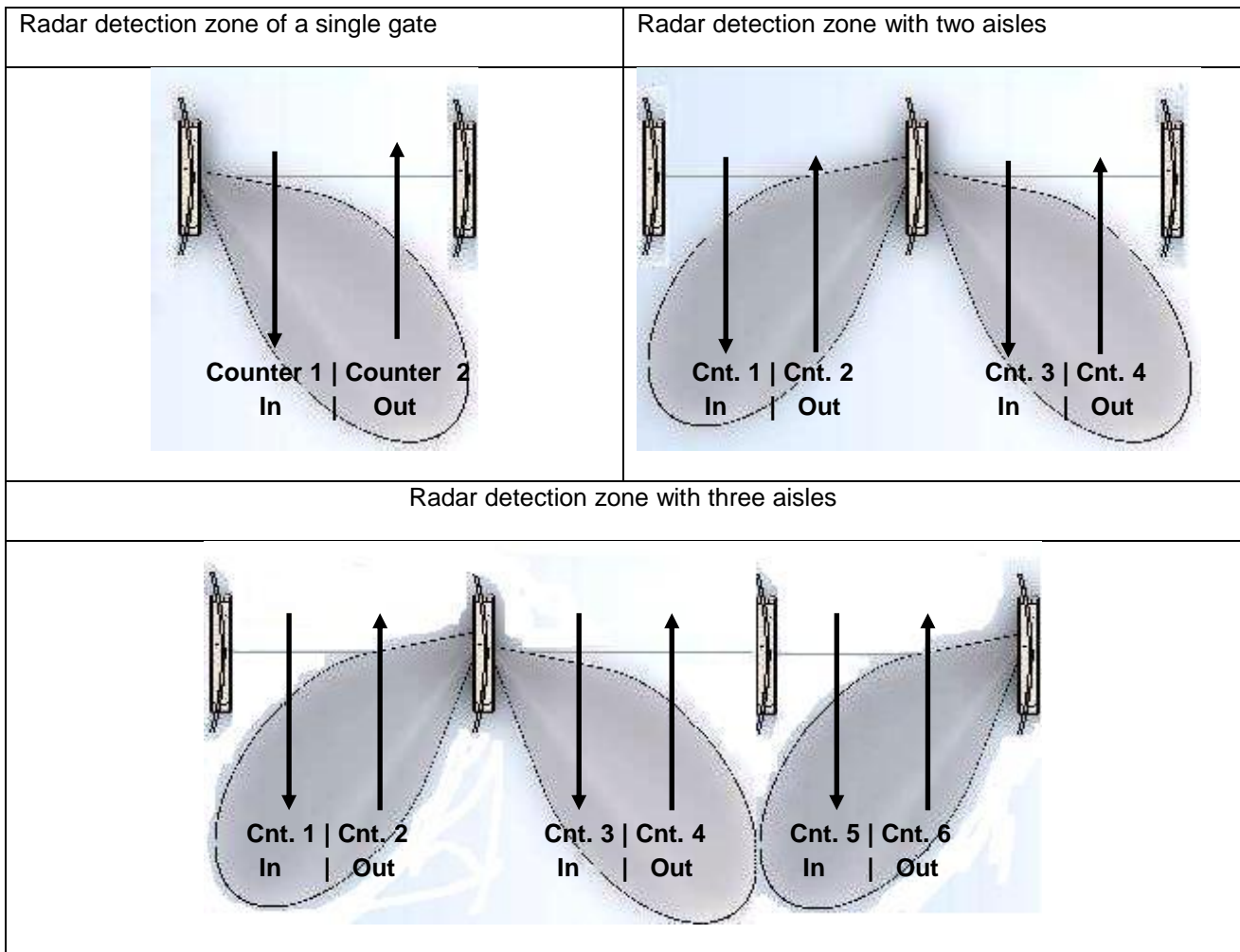

Fig. 2: Top view of the detection areas (2-4 antennas, 1-3 gate aisles)

The people counter board and the radar detectors are mounted in the base of the antenna. As the radar beam can pervade the plastic housing of the antenna, no openings are required.

The connection between reader and people counter is established via the RS485 interface of the reader, inside the antenna.

A direct connection from the GPC to the host is not required. All commands from the host to the people counters are embedded in the piggyback command of the reader.

Generally, there are two possibilities to get the current people counter values. Either the host polls the people counter periodically or in Notification Mode, the reader sends a notification protocol for each change.

In ISO Host Mode or Buffered Read Mode, the host polls the GPC by sending protocols. Only, in Notification Mode, the reader automatically polls the people counter values and sends data to the host according to the reader configuration.

See also System Manual H01011-0e-ID-B.DOC

### 5.3 Available Antenna Types

The following products are currently available:

Antenna Type	Description
ID ISC.ANT1710/690-A Crystal Gate Excellence Order No. 5319.000.00	Antenna with Reader, Multiplexer, two dynamic tuning boards ID ISC.DAT, signal LED, alarm buzzer, People Counter Board and radar detector .
ID ISC.ANT1710/690-B Crystal Gate Excellence Order No. 5318.000.00	Antenna with two dynamic tuning boards ID ISC.DAT and signal LED
ID ISC.ANT.GPC Gate People Counter Order No. 4704.000.00	People Counter and radar detector for antenna ID ISC.ANT1710/690 incl. mounting and cabling set. (optional)
ID ISC.ANT.GPC-E2 Extension Radar Detector Order No. 4718.000.00	Second radar detector with cable for the second direct parallel aisle (optional)
ID ISC.ANT.CRG-MP Crystal Gate Mounting plate Order No. 4412.000.00	Metal mounting plate for easy installation, soft ground and drilling template. (optional)
ID ISC.ANT.CRG-DT Crystal Gate Drilling Template Order No.3827.000.00	Drilling Template and mounting plate for soft grounds.

Table 1: Available antenna types and accessories

Required components to setup a gate by using the Gate People Counter:

Number of antennas	Antenna		People Counter (Optional)		Note
	ID ISC. ANT1710/690 - A	ID ISC. ANT1710/690 - B	ID ISC. ANT.GPC	ID ISC.ANT. GPC-E2	
2 Antennas	1	1	0		
3 Antennas	1	2	0	1	
4 Antennas	1	3	1 (ANT4)	1	

Table 2 Required components for gates with people counter

## 6 Installation and Wiring

### ① NOTE:

- ***Before installing the antennas please read 7.1 Project Notes Antenna. The spacing of the antennas in a gate depends on the antenna configuration.***
- ***If multiple antennas or gates are connected to different readers, a minimum clearance of 8 m must be kept between the antennas or gates. For shorter distances (1 m – 8 m) the readers must be synchronized. The synchronization of the readers (see application note N10311-xe-ID-B.doc) is only possible in one of the Reader Automatic Modes.***
- ***At a distance below 1.5 m the antennas must be shielded from each other. Otherwise, the read range will be significantly reduced.***
- ***The antennas must have a minimum distance of 20 cm to all larger metal parts! At a distance of less than 50 cm between the antenna and metal parts the read range will be significantly reduced.***

### 6.1 Mounting Preparation

To mount the antenna, unpack it carefully and open the antenna base. This is done as described in the following steps:

1. Place the packed antenna on the floor with the top side facing up. Carefully open the box and then remove the antenna.



Fig. 3: Packed Antenna

2. Afterwards, the antenna must be carefully placed on the floor again. Now the two fastening screws (hexagon socket AF 2,5) must be removed from the antenna base cover. Carefully remove the cover from the antenna base by sliding it upwards (Fig. 4).



**IDENTIFICATION**

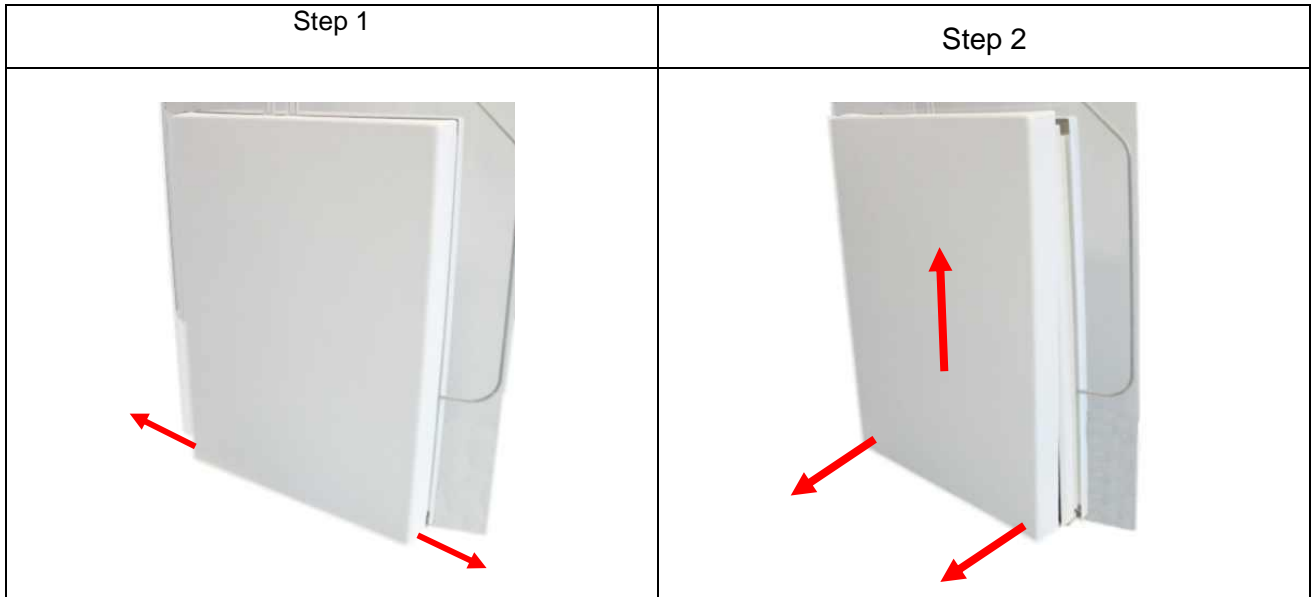

Fig. 4: Opening the antenna base



## 6.2 Installing the Antenna

### 6.2.1 Dimensions of the Antenna

The overall dimensions of the antenna are shown in Fig. 5

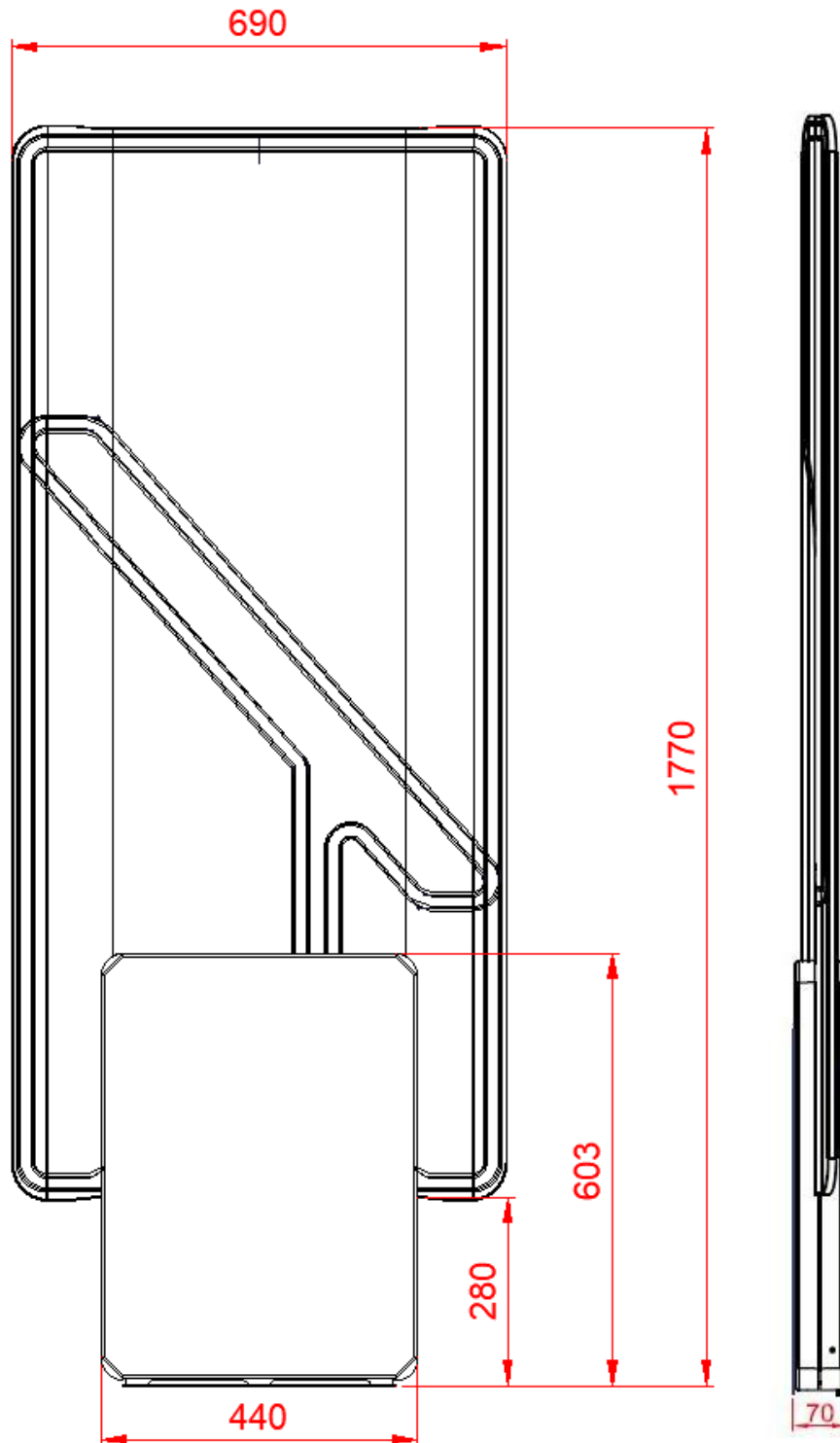

Fig. 5: Antenna outside dimensions

All dimensions are in mm with general tolerance according to ISO 2768 m (mean).

### 6.2.2 Drilling the Mounting Holes

If the position of the antennas has been marked or determined, the mounting holes and the holes for the cable entry, can be marked and drilled. To make this easier the ID ISC.ANT.CRG-DT Crystal Gate Drilling Template or the ID ISC.ANT.CRG-MP Crystal Gate Mounting plate can be used (optional). This mounting plate can also be used for stabilization and weight distribution on soft grounds by mounting it additionally under the antenna foot. The dimensions are shown in Fig. 6:

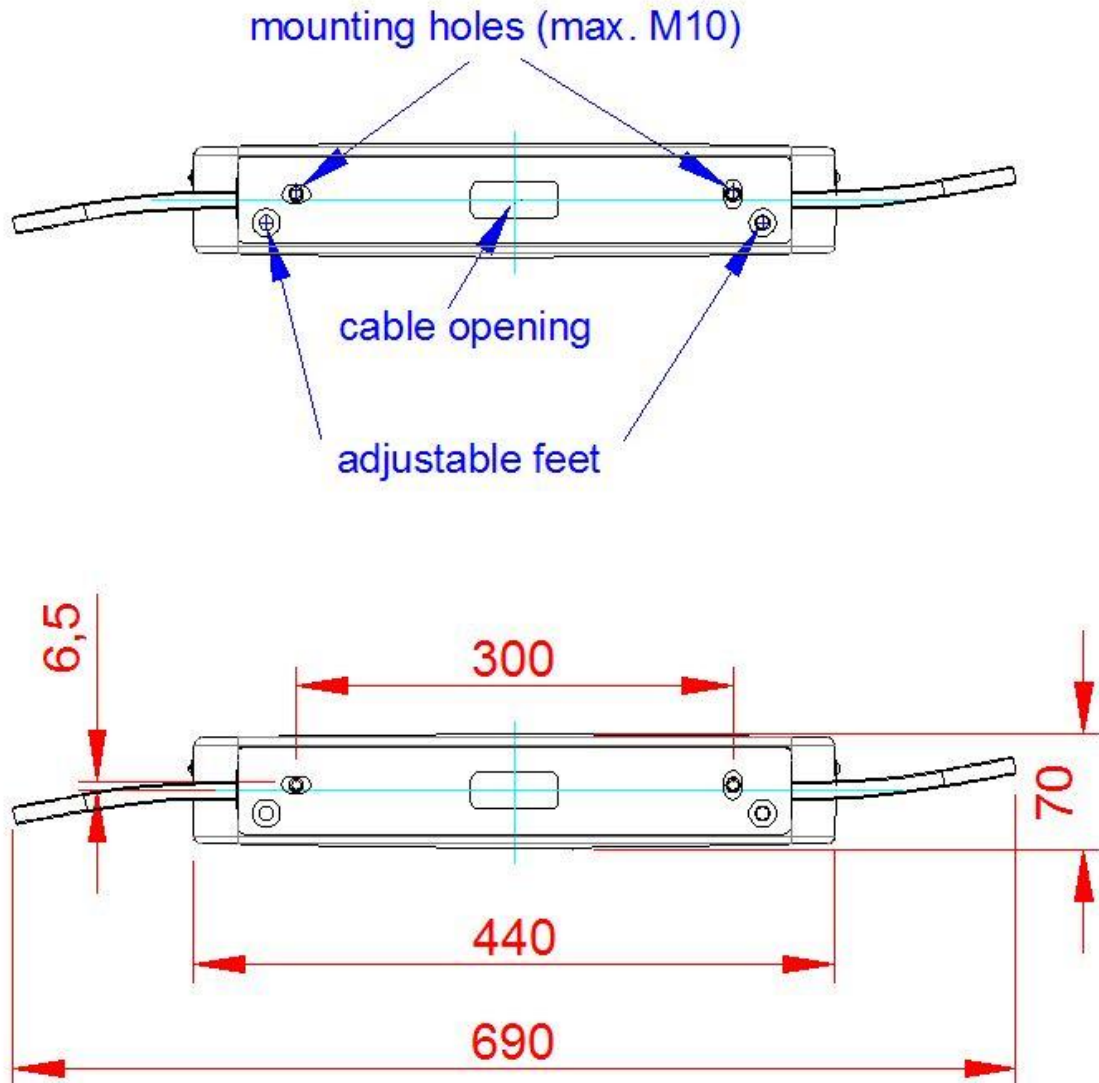

Fig. 6: Floor plate dimensions

All dimensions are in mm with general tolerance to ISO 2768 m (middle).

The size and type of the anchors depend considerably on the strength of the floor. The anchors should be capable of withstanding a permissible load of at least 5 kN per anchor for all load directions (e.g. for concrete floor Hilti HVA anchors with HAS-(E) M8 threaded rod or Hilti HIS-N M8 (5/16") threaded inserts). The size of the mounting holes in the antenna is 10 mm (3/8"). The length of the anchors or bolts should be selected so that they are at least 40 mm (1.6") and maximum of 55 mm (2.2") from the floor.

**Please follow the mounting instructions of the anchor manufacturer!**

**IDENTIFICATION**

A cable opening is provided for the necessary connection cable (see Fig. 6). The cable opening is dimensioned so that up to 10 cables with a diameter of 6 mm can be led through the opening.

If some empty tubes should be installed in advance in the floor we recommend a tube diameter of minimum 30mm diameter and at multiple antenna setups with more than 3 antennas a diameter of 50mm

Alternatively, the cables can be routed at the sides of the antenna foot, as shown in

Fig. 7.

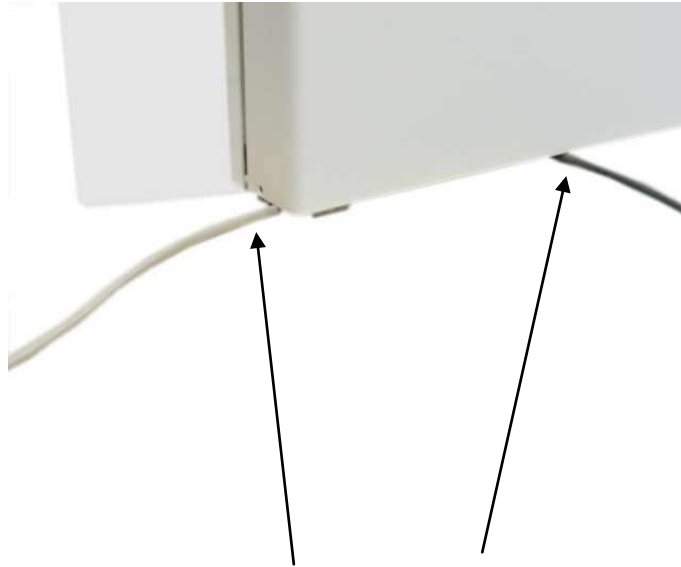

Fig. 7 Cable routing at the antenna sides

### 6.2.3 Installing the Antenna Base and Antenna Body

The antenna is mounted on the floor. Please note that the antenna conductors in the middle of the antenna body must have the same direction (

Fig. 8).

Afterwards, the antenna must be aligned vertically, by using the adjusting screws (Fig. 9). Please read 8.3.4 Using the Trigger Function of the Gate People Counter and 7.2 Project Notes People Counter (GPC).



Fig. 8 The shape of the conductors must have the same direction

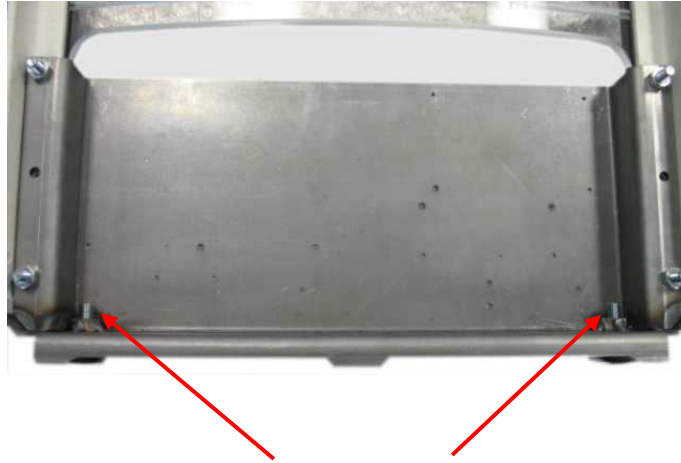

Adjusting screws (hexagon socket width AF 4)

Fig. 9: Attaching and aligning the antenna

## 7 Typical Antenna Configuration (Gate Antenna with two Antennas)

The standard configuration of a gate with three-dimensional tag orientation consists of one ID ISC.ANT1710/690-A Crystal Gate Excellence with reader and multiplexer and one ID ISC.ANT1710/690-B Crystal Gate Excellence. If a tag moves horizontally through the gate, it can be read at least once. This ensures high reliability of the antenna system.

### 7.1 Project Notes Antenna

The described antenna configuration allows the detection of a tag moving on a horizontal line through the reading area of the gate. The tag orientation is arbitrary. The tags are detected along a horizontal axis of motion in certain areas within the antennas. The area of detection depends on the tag orientation.

The size of the three-dimensional reading area of the antennas is shown in the sketch below.

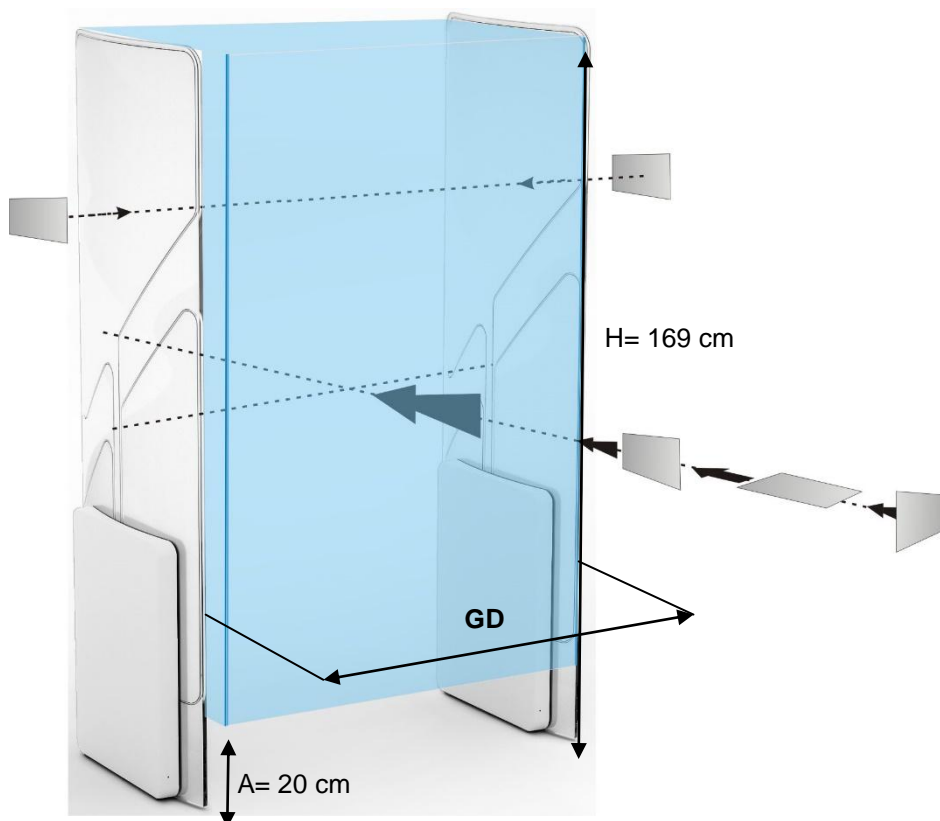

Fig. 10: Capture area and tag orientation

#### NOTE:

- Note that the entire reading area of the antenna gate is larger than the three-dimensional area shown in the drawing ( Fig. 11). This means there are tag orientations in which the tag can be detected outside the reading area.
- To achieve optimal performance, the reader must be configured and operated in one of the Reader Automatic Modes (Buffered Read, Notification or Scan Mode).
- If multiple gates are arranged at short distances (1-8m) from each other, they interfere with each other. In this case, the readers for the individual gates must be synchronized and operated in one of the Reader Automatic Modes.

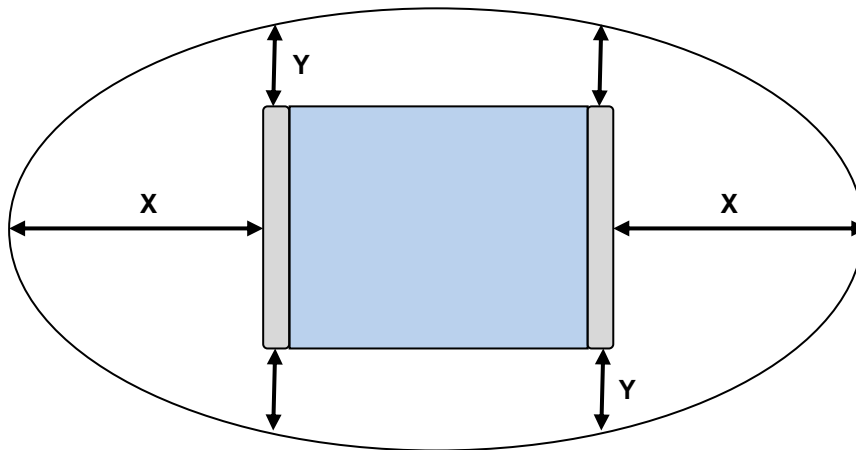

Fig. 11: Top view, detection area outside of the antenna gate

Direction	Minimum Distance
right, left (X=)	80 cm
front, behind (Y=)	40 cm

Table 3: Capture area, unintentional detection

To achieve three-dimensional reading of the tag in the reading area shown above (Fig. 10), the following conditions must be fulfilled:

- The gate distance (GD) depends on the antenna configuration (see Table 5).
- The tags should be at least ISO card size (46 mm x 75 mm).
- The activation field strength of the tags should be less than or equal to 60 mA/m.
- The distance from tag to tag should be greater than 10 cm. If the distance from tag to tag is reduced, the gate distance GD must be reduced correspondingly. This applies in particular to distances under 5 cm.
- The maximum number of tags (serial number or data) depends on the speed at which the tags pass through the detection area of the gate (see Table 5). The number of tags may be increased if the gate distance GD is correspondingly reduced and the maximum speed is adjusted accordingly.
- The antenna should be at least 50 cm away from metal parts.
- The minimum distance between the antennas of a gate and other antennas of RFID workstations or terminals (transmitting frequency 13,56 MHz) should be:

Transmitted output power	Minimum Distance
< 0.5 W	1 m
0.5 W-1.0 W	2 m
1.1 W – 2.0 W	3 m
> 2 W	4 m
>= 4 W	8 m

Table 4: Minimum Distances

- The reader must not be disturbed by other electrical devices in the environment. The difference in noise level should be less than 20 mV.

**IDENTIFICATION**

- The ID ISC.LRM2500 reader should be set to an RF power of 4 watts.
- When using ISO 15693 transponders, the readers should be set as described in 7.3.6 Reader Configuration with Multiplexer
- If multiple gates are operated at the same time at a distance of less than 8 m, the readers must be synchronized. See Application Note *Synchronizing RFID Long Range Readers using the digital in-/outputs* (N10311-xe-ID-B.pdf).

	Gate with antenna Type A and Type B
Gate distance GD	≤ 100 cm
Number of tags at a speed of 1 m/s	
Read serial number	16
Read data	8

Table 5: Gate distance

Supplementary equipment (e.g. light barrier, lighting, etc.), mounted directly on the antenna or in the immediate vicinity of the antenna can interfere with the function of the system.

A minimum distance of 20 cm is required.

Electrical cables, directly at the antenna or in the immediate vicinity of the antenna, can cause interference.

A minimum distance of 20 cm is required.

A minimum distance of 65 cm between the two gate antennas is required.



## 7.2 Project Notes People Counter (GPC)

The radar sensor of the people counter detects moving objects within the detection area (A1, A2, see Fig. 13) of the radar antenna. The size of the detection area and hence the sensitivity of the devices can be adjusted with the ISOStart software (see 8.3.2 Configuration and Test in ISO Host Mode or Buffered Read

A door (including glass doors), curtain and, in particular, automatic doors or other moving objects can strongly influence the counting of the people counter.

If a people counter is installed in the antenna, the antenna conductors in the middle of the antenna body must be aligned so that the red arrows as shown in



Fig. 8 (The shape of must have the same the direction of the

the conductors direction) point in free space.

**IDENTIFICATION**

Library Interior

Fig. 12: Direction of antenna conductor in front of Library door

This means that if the antennas are installed near the entrance and exit, the detection area of the radar sensors must point away from the door. Otherwise, a minimum distance of 1.0 m between moving objects and detection areas must be maintained.

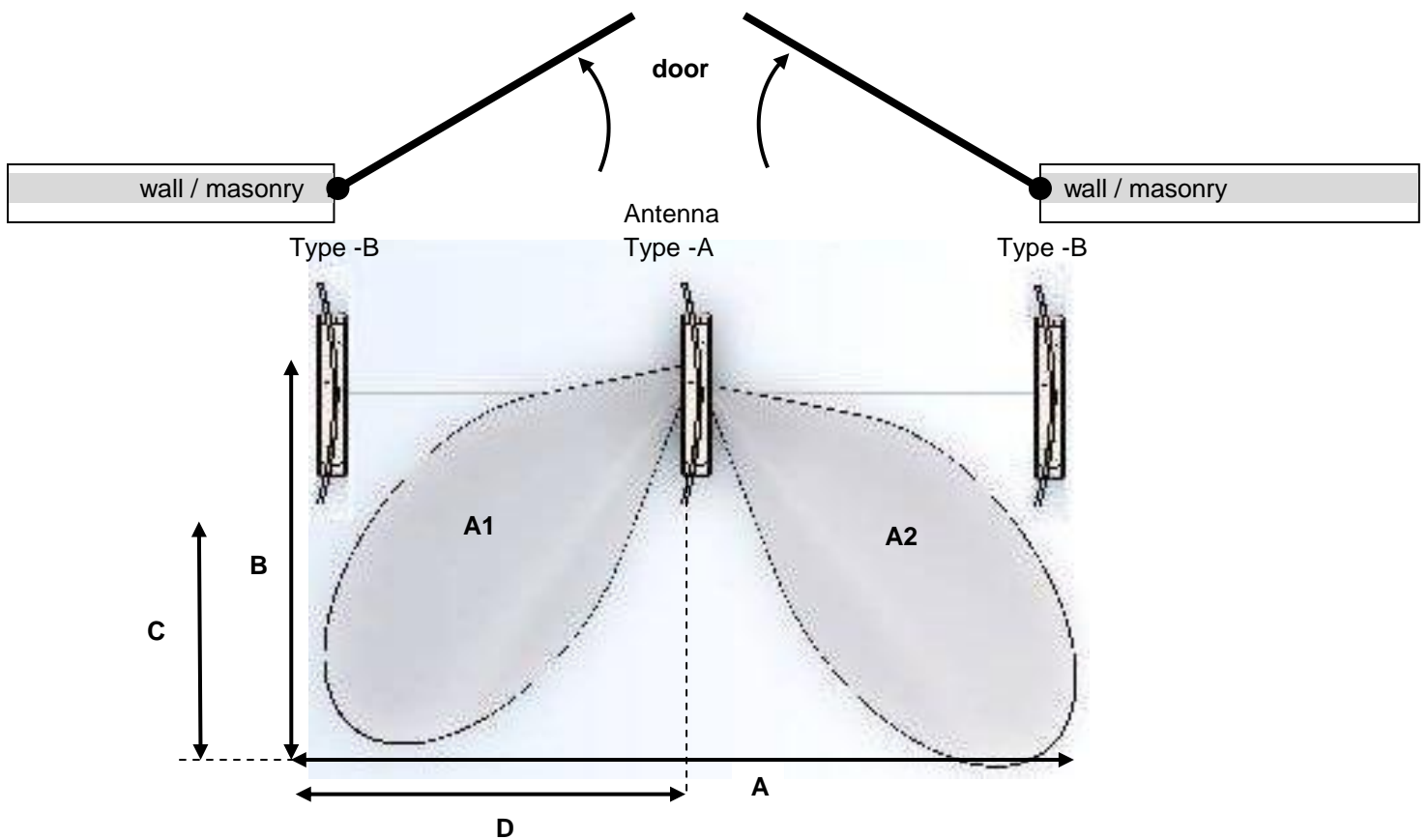

Fig. 13: Top view: detection area A1 und A2 (Foot print) of the radar sensor

Sensitivity	Low	Medium	High	** Very high
Distance A	180 cm	200 cm	200–220 cm	240–260 cm
Distance B	60–70 cm	80–90 cm	100–110 cm	120–130 cm
Distance C	20–30 cm	40–50 cm	60–70 cm	80–90 cm
Distance D	90 cm	100 cm	100–110 cm	120–140 cm

Table 6: Detection area radar sensor, antenna distance 1m

**\*\* Standard configuration**

All values are approximate values, depending on the size of the objects, the behavioral reflection of the floor and the material of the moving object.

At distances  $D > 140$  cm, reduce the accuracy of the systems.

If two people (or moving objects) move simultaneously within the detection area of a radar sensor, usually only one person is counted.

The minimum distance between two persons, so that these persons are detected separately, is 60 cm to 130 cm, depending on the sensitivity and position in the passage.

Cross traffic in the detection area, i.e. people who cross in front of the antennas, go from left to right (or contrariwise), can also be counted or recorded.

To avoid interference, the detection area of radar motion detector mounted above or at automatic doors (operating frequency 24.125 GHz) must not overlap with the detection area of the people counter.

**① NOTE:**

- ***The People Counter is designed to obtain statistical values on visitor flows. For persons with small distances, due to interferences and cross traffic, the determined values of the actual values can vary.***
- ***If major deviations are noticed, first the sensitivity of the radar sensors should be gradually reduced.***

**7.3 Gate Configuration and Setup Using Antennas****7.3.1 Required Components**

To set up the gate you need the following components:

- 1 ID ISC.ANT1710/690-A Crystal Gate Excellence (Base)  
(incl. 1 ID ISC.NET24V-B Power Supply Unit)
- 1 ID ISC. ANT1710/690-B Crystal Gate Excellence
- power cable, interface cable and connection cable for the DC power supply (2-wire, twisted)
- mounting materials (screws, anchors)

To calibrate the reader, you need the software

## IDENTIFICATION

---

- ISOStart 2019 Version 10.05.xx or higher

and for tuning the antennas the service software

- DATuningTool Version 1.02.02 or higher

on a computer running Microsoft® Windows®. The software can be downloaded from the download area at [www.feig.de](http://www.feig.de).

**IDENTIFICATION**

7.3.2 Configuration of a Gate Antenna with Multiplexer

Connect the components as shown in Fig. 13. Almost, all cables should already be installed. Normally the antenna cables from antenna Type B have to be connected to the multiplexer at OUT3+4 (see also [7.3.3 Setting the Multiplexer](#)) and the 24V DC power supply at X11 of the terminal board. Also a connection between X13 GPC-out of the terminal board in Antenna Type A and X13 GPC-out of the terminal board in Antenna Type B must be installed to supply the LED with power and RS485 bus.

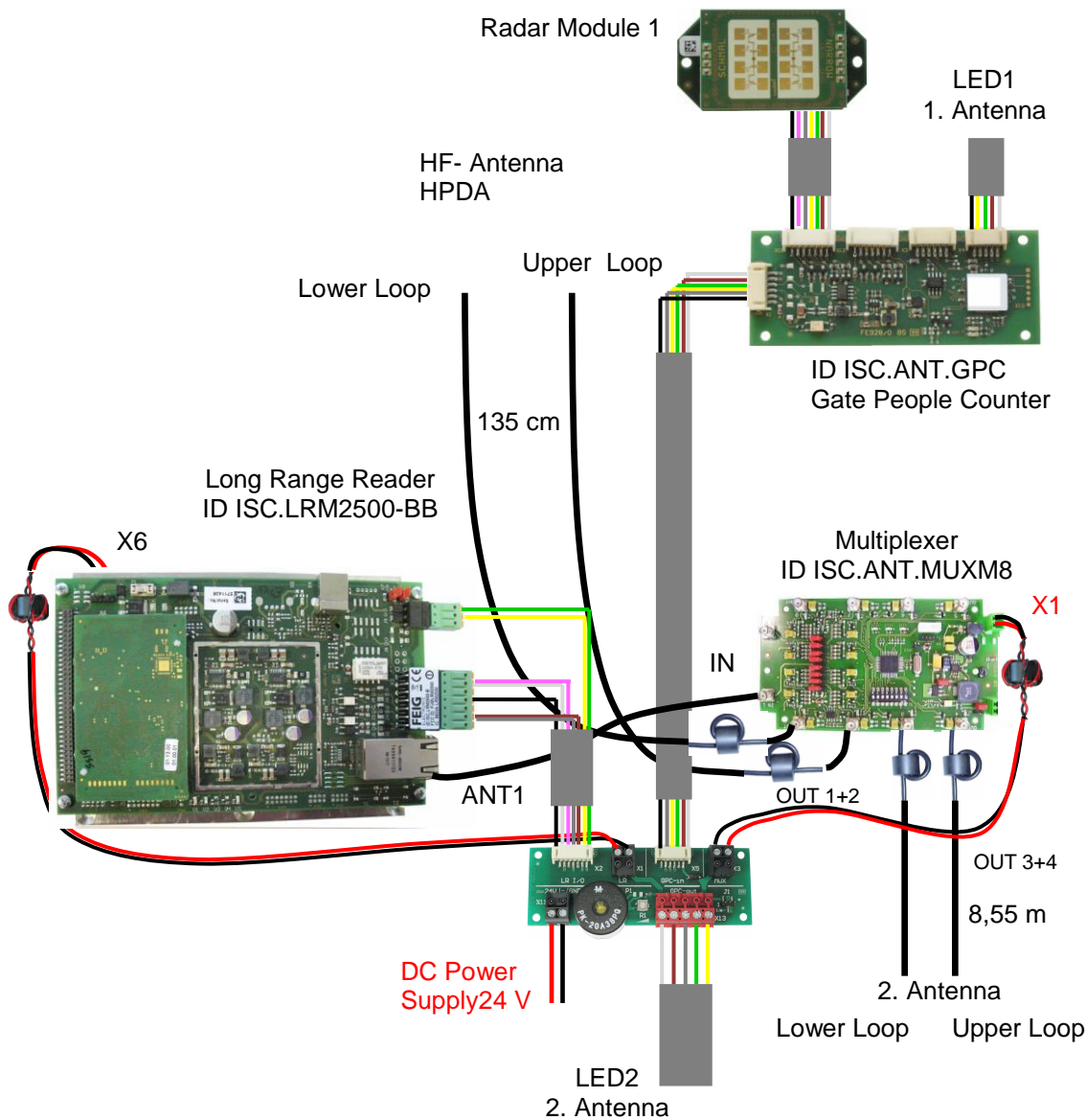

Fig. 14: Connecting the components for a gate consisting of two antennas, reader and multiplexer

**IDENTIFICATION**

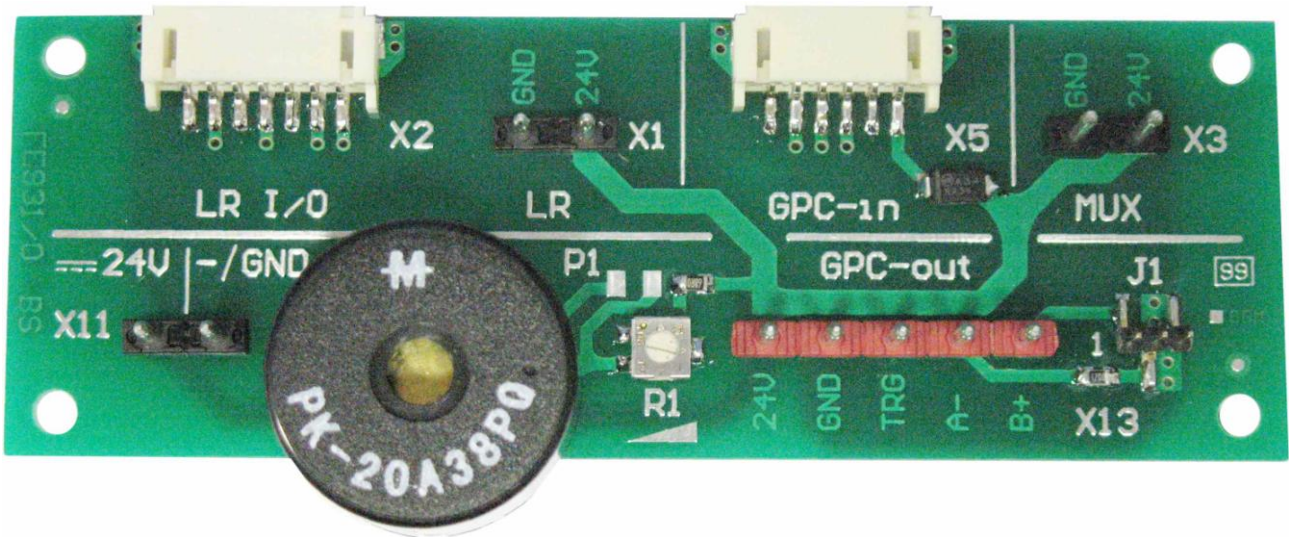

Fig. 15: Terminal board

An overview of the terminal board assignment is given in [Annex A: Terminal Assignment “Terminal Board”](#)

**NOTE:**

**A reverse polarity could damage the device or the In-/Outputs.**

The connection between antenna Type A and Type B must be made with the data cable included in the contents of antenna Type B. The ferrite core should have 3 turns of the cable approx. 7cm at the cable end.



Fig. 16: Data cable



**IDENTIFICATION**

Here you find a possible wire connection between antenna Type A and B:

At a single gate with 2 antennas, a connection must be installed between X13 GPC-out of the terminal board in Antenna Type A and X13 GPC-out of the terminal board in Antenna Type B. The side with the ferrite core must be placed in the antenna Type B.

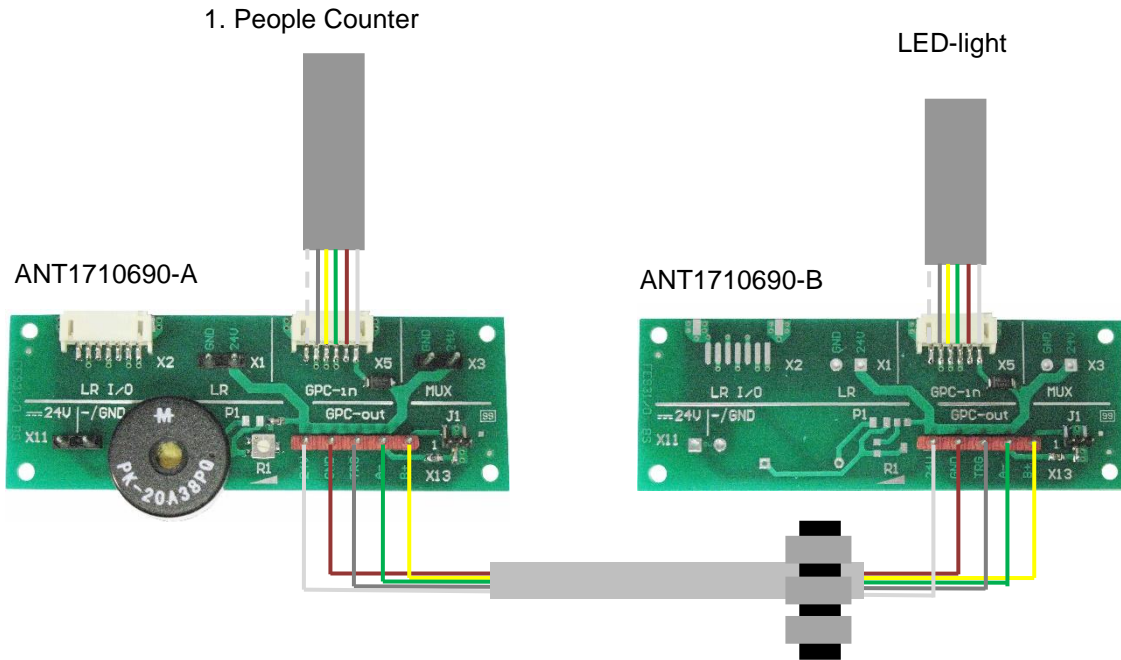

Fig. 17: Connection of the antennas at single gate

Possible configuration for a double gate with 3 antennas:

X13 GPC-out of the terminal board in Antenna Type A and X13 GPC-out at the 1st Antenna Type B and X13 GPC-out of the terminal board in Antenna Type A and X13 GPC-out at the 2nd Antenna Type B must be installed. The sides with the ferrite core must be placed in the antenna Type B

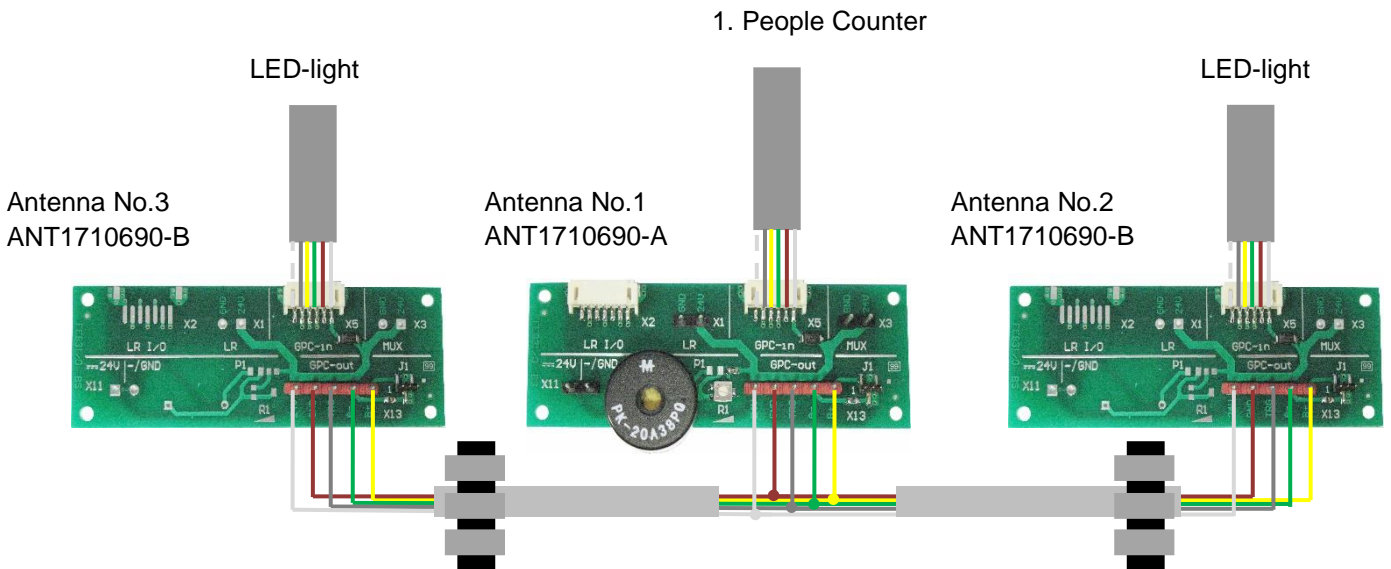

Fig. 18: Connection of the antenna at double gate

Basically X13 GPC-out of the terminal boards of all used antennas must be connected from antenna to antenna 1:1 in parallel.

**IDENTIFICATION**

The coax cables have fixed lengths and must not be shortened and therefore need to be tied into small loops (see Fig. 19). Tie all cables as far away from the antenna conductor as possible. The cables must never touch the antenna conductor. Unused cable lengths (e.g. of interface cable) should not be placed in the area above the reader and multiplexer. The power supply should not be placed in the Type A antenna.

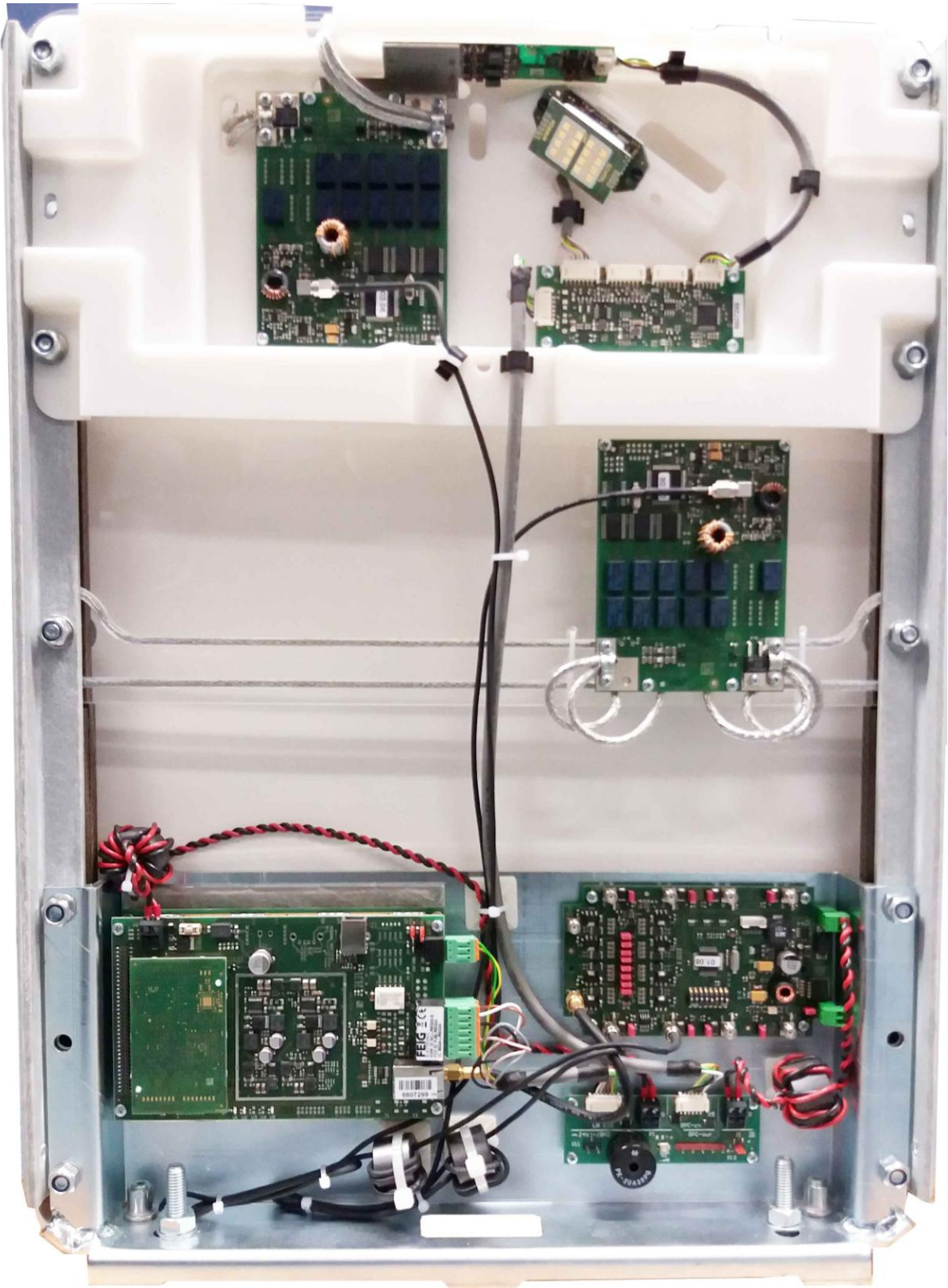

Fig. 19: Connection of the components in an antenna Type A



**IDENTIFICATION**

The cable from antenna type B to the antenna type A should preferably be connected shortly. Unused cable lengths should be tied in antenna Type B. Tie all cables as far away from the antenna conductor as possible. The cables must never touch the antenna conductor. It is possible to place the power supply in the foot of the antenna Type B. The ferrite cores must be placed after installing the cables 10cm at the cable end of the cable in antenna type A with 3 turns at each cable.



Fig. 20: Unused coaxial cables must be fixed in antenna Type B

**IDENTIFICATION**

**7.3.3 Setting the Multiplexer**

The jumpers JP11-JP18 should be set (factory setting) as shown. For more information on setting the ID ISC.ANT.MUX.M8 Multiplexer, refer to the corresponding installation manual (M90700-xde-ID-B).

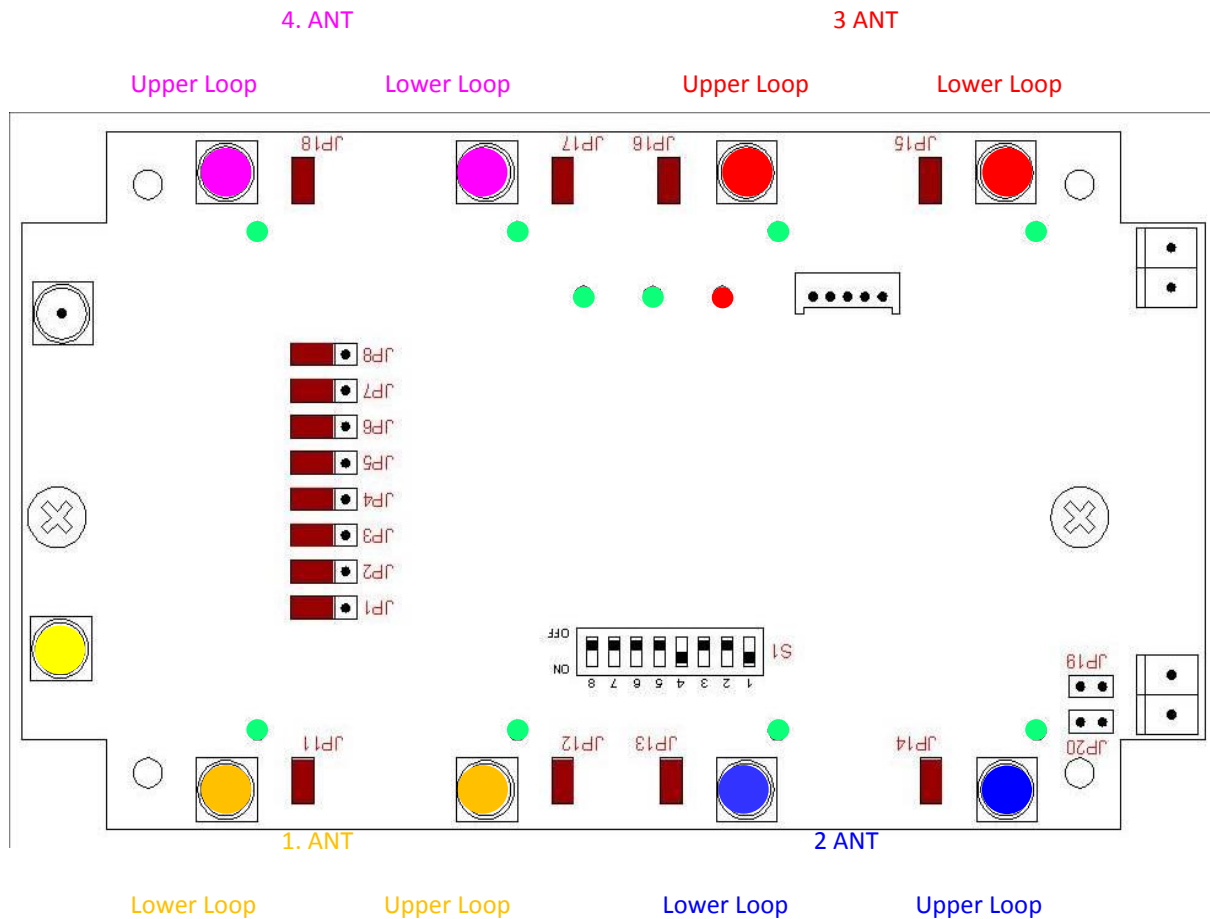

Fig. 21: Jumper positions and antenna connections

Antenna 1: Type A: Lower loop is connected by default with output 1 and upper loop with output 2 of the multiplexer (orange).

Antenna 2: Type B: Lower loop has to be connected to output 3 and upper loop to output 4 of the multiplexer (blue)

Antenna 3: Type B: Lower loop has to be connected to output 5 and upper loop to output 6 of the multiplexer. (red)

Antenna 4: Type B: Lower loop has to be connected to output 7 and upper loop to output 8 of the multiplexer. (pink)

**IDENTIFICATION**

**7.3.4 Setting the Antenna Tuner**

To check the settings of the antenna tuner, the antenna base has to be opened. To do this, remove the two fastening screws (hexagon socket AF 2,5) from the antenna base cover. By carefully moving the cover upwards, remove the cover from the antenna base.

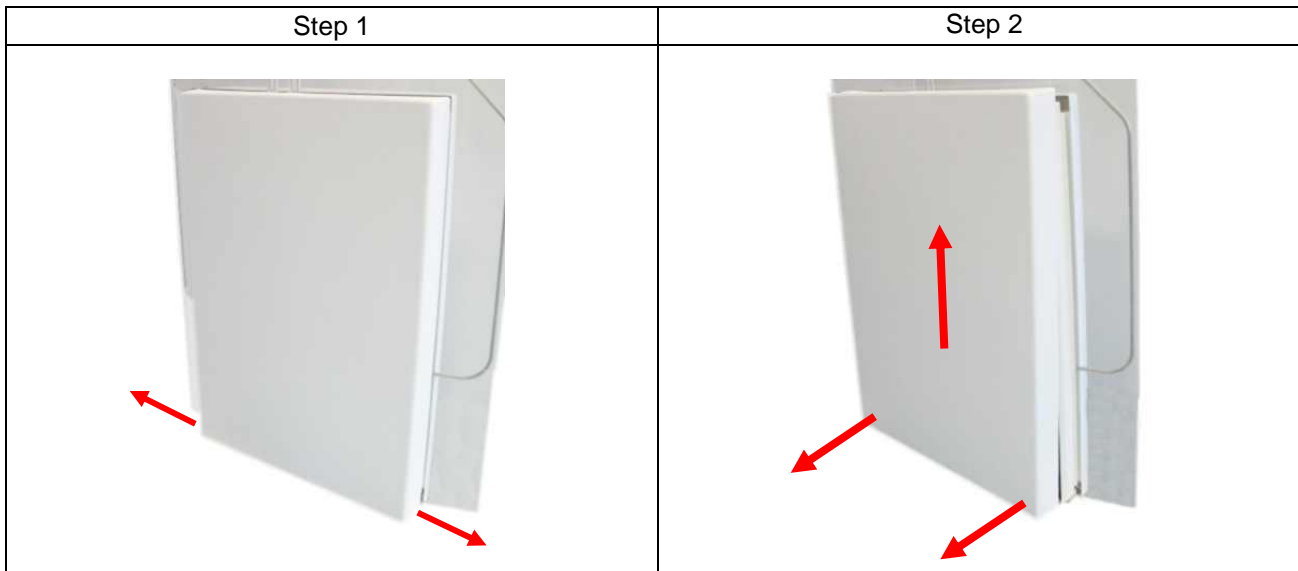
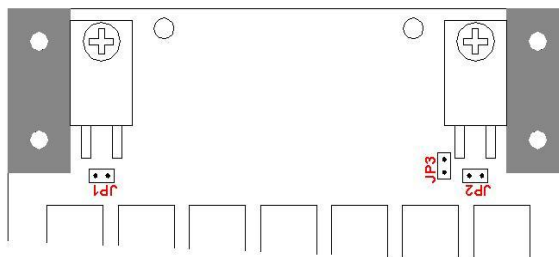

Fig. 22 Removing the antenna base covers

The jumpers JP21-JP24 of the Dynamic Antenna Tuning board should be set (factory setting) as follows:

Function	Jumper	Position
Capacitor C1 Upper and Lower Tuning Board	JP11,12,13,14	open
Capacitor C2 Upper Tuning Board	JP21,22,23,24,25,26	open
Capacitor C2 Lower Tuning Board	JP21,22,25,26 JP23,24	open closed
Resistors Antenna switch	JP1,2 J3	open open

Table 7: Jumper settings for antenna tuner



Verify these settings. For more information on setting the ID ISC.DAT antenna tuner, refer to the corresponding installation manual (M40401-xde-ID-B).

**IDENTIFICATION**

7.3.5 Interface Connections

7.3.5.1 LAN / TCP/IP

The reader has an integrated 10/100 Base-T network port for an RJ-45 connector. The connection is made to X1 and has an automatic “Crossover Detection” according to the 1000 Base-T Standard.

**X1**

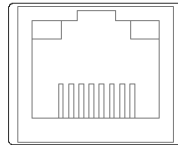

Fig. 23: LAN interface for host communication

With structured shielded cabling CAT-5 cables should be used. This ensures reliable operation at 10 Mbps or 100 Mbps.

The prerequisite for using TCP/IP protocol is that each device has a unique address in the network. All readers have a factory-set IP address.

Network	Address
IP-Adresse	192.168.10.10
Subnet-Mask	255.255.255.0
Port	10001
DHCP	OFF

Table 8 Standard factory configuration of the Ethernet connection

**NOTE:**

***The Reader TCP/IP interface has a DHCP option.***

For more information on the interfaces, refer to the manual M81010-xe-ID-B of the reader.



**IDENTIFICATION**

7.3.6 Reader Configuration with Multiplexer

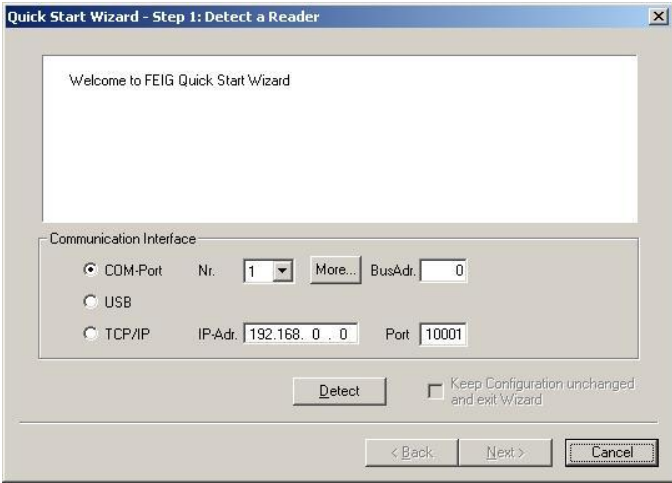
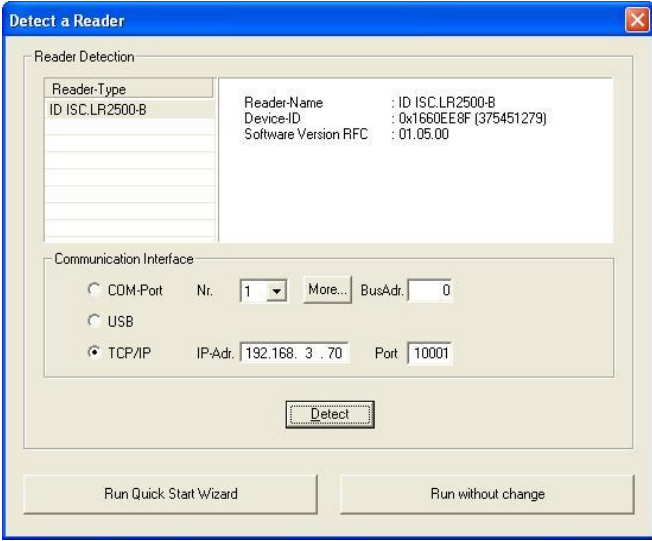
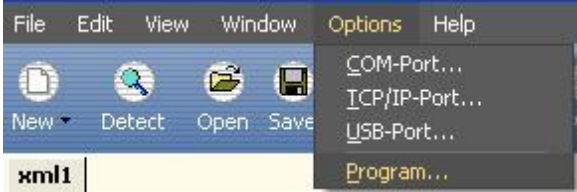
To tune the antennas, open the ISOStart software and read out the current configuration of the reader:

Step	Action	Note
1	Start ISO Start Software	
2	Select „Detect“	
3	Select „Run without change“ Note: This has to be done at each start of ISO-Start program otherwise the configuration of the reader will be changed by the wizard.	
4	Select „Options => Program“	

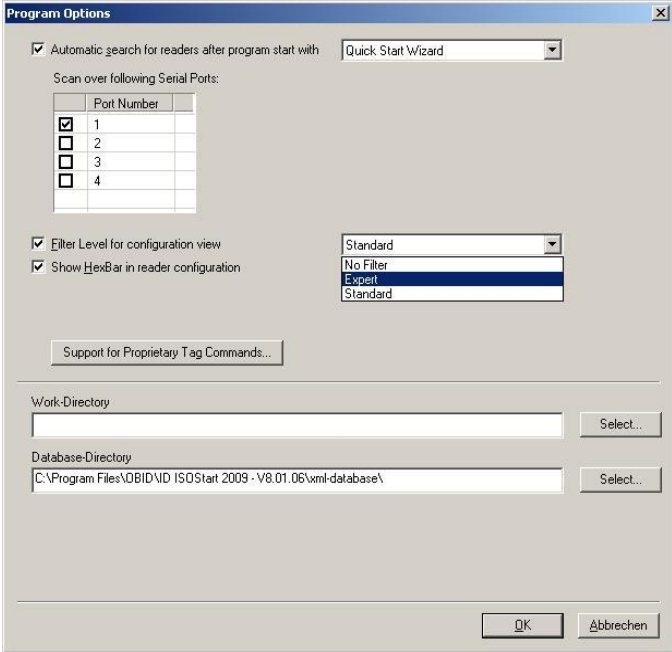





**IDENTIFICATION**

Step	Action	Note
5	Select „Expert Mode“ and confirm with OK.	
6	Select “Logical View”	

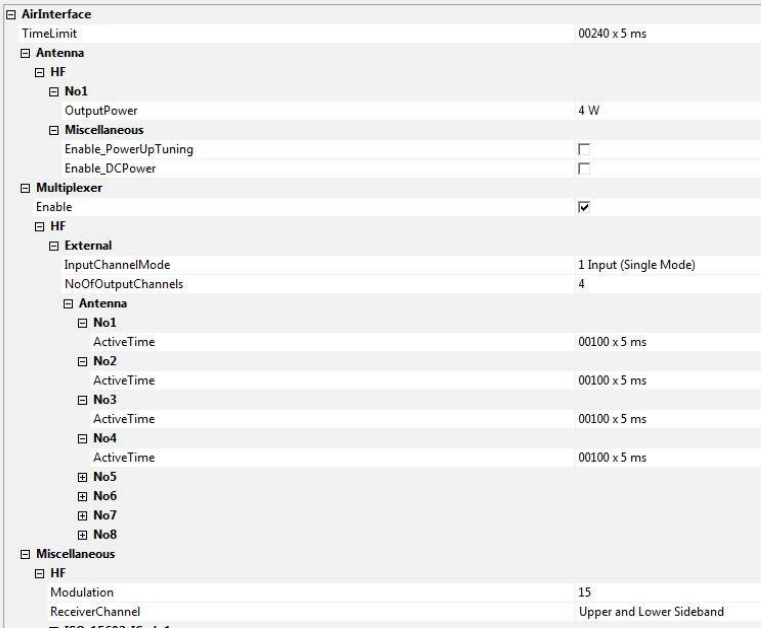

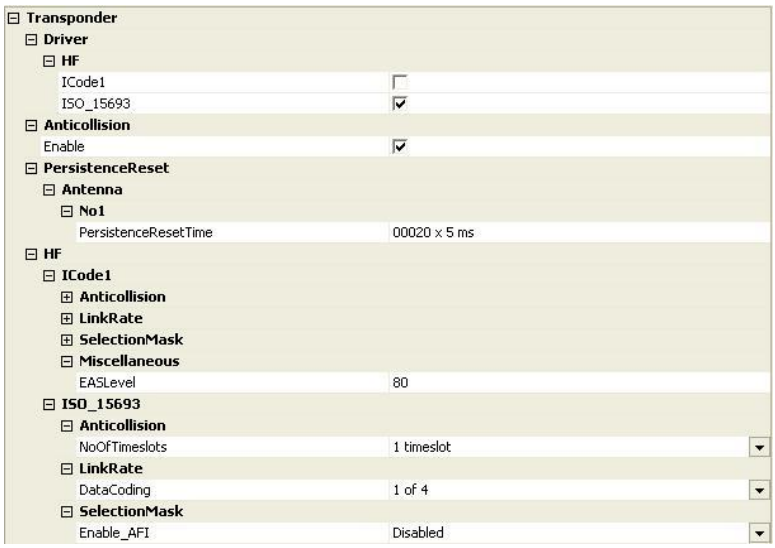
**IDENTIFICATION**

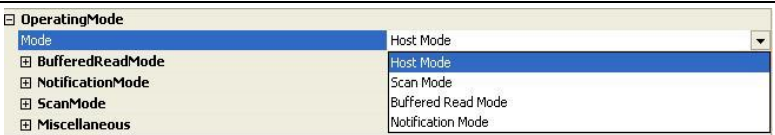



Afterwards set the operating power, Transponder Parameters and ISO Host Mode:

Step	Action	Note
1	Select "Configuration"	
2	<p><b>Air Interface:</b></p> <p>"Output -Power" = 4W</p> <p>„Multiplexer Enable“</p> <p>„1 Input (Single Mode)“</p> <p>„No of Output Channels „ (4 = one aisle) (6 = two aisles) (8 = three aisles)</p> <p>„Antenna Active Time“ 100 x 5ms</p> <p>“Receiver Channel” Upper and Lower Sideband</p>	
3	Set by clicking on „Apply“.	
4	<p><b>Transponder:</b></p> <p>Configure the parameters as following:</p> <p>„Driver“ – here ISO 15693</p> <p>„Anticollision“ – enable</p> <p>„No of Timeslots“ – 1 timeslot</p> <p>„Data Coding“ – 1 of 4</p> <p>„AFI“ – Disabled</p>	 <p>Note: National RF regulations may require different settings (see 9 Reader Configuration in Accordance with National RF Regulations).</p>
5	Set by clicking on „Apply“.	
6	<p><b>Operating Mode:</b></p> <p>For antenna tuning the reader has to be set to „Host Mode“ .</p>	
7	Set by clicking on „Apply“.	

**IDENTIFICATION**

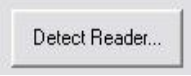
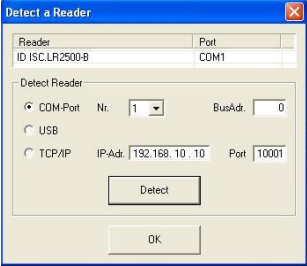
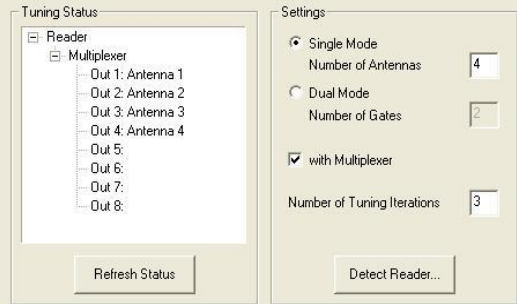
7.3.7 Tuning the Gate Antenna

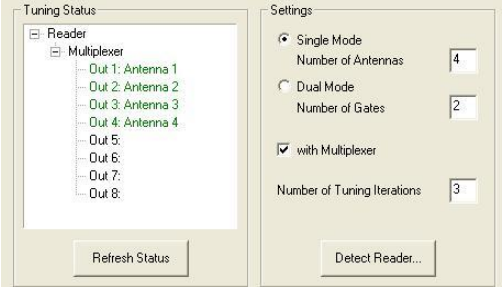
Before tuning the gate antenna, you must quit the ISOStart software. Then the gate can be tuned as follows:

Step	Action	Note
1	Start "DATuningTool" software	
2	Select "Detect Reader...". In the „Detect Reader“ window select the interface (COM-Port 1, BusAdr. 0) and then click on "Detect".	 
3	Use „Settings“ to enter the configuration: Single Mode, Number of Antennas e.g 4 Click on "with Multiplexer" Number of Tuning Iterations 3	
4	Activate „Start Tuning“ and wait until the tuning process is finished.	 
5	The tuning status is displayed after each tuning pass. After successful tuning both antennas are shown in green.	
6	If this does not succeed on the first try, start the process again by clicking on „Start Tuning“	

After successful tuning, close the DATuningTool.



**IDENTIFICATION**



**7.4 Testing the Gate Antenna**

After tuning the gate antenna, you can check for proper function using a reader, the ISO-Start service software and a transponder. At this point, the noise level and performance of the gate are tested.

**7.4.1 Checking the Noise Level**

Step	Action	Note
1	Activate antenna 1 with the command: „Function Unit Commands - Multiplexer“ Parameter: „Channel Select“ „Cascade Level = 1“ „Output Channel of Input 1 = 1“	
2	Confirm with “Send”	
3	Activate “Test and Measurement”	
4	Select „Noise Level“ and start by clicking on „Start“	
5	Normal Noise Level values: Average: < 30mV Difference (Max-Min): < 20mV	

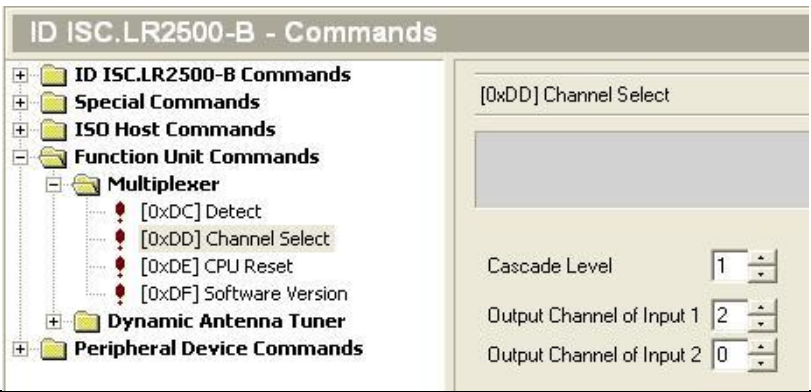
**IDENTIFICATION**

Step	Action	Note
6	Activate antenna 2 with command: „Function Unit Commands - Multiplexer“  Parameter: „Channel Select“ „Cascade Level = 1“ „Output Channel of Input 1 = 2“	
7	Confirm with “Send”	
8	Repeat Step 3 to 5 for every further antenna	





If the values are inaccurate, check the following:

- Are all cables pulled tight and in good contact?
- Are the ferrite ring cores installed on the antenna cable?
- Are the cables routed as specified?
- Are there other RFID systems installed nearby?
- Are there large metal parts close to the antenna (distance < 1.0 m)?
- Are there any devices nearby which may emit noise interferences (larger machines or wireless devices)?
- Are there interferences from the power supply?

To determine which devices may interfere with the gate, briefly disconnect them from the power supply.

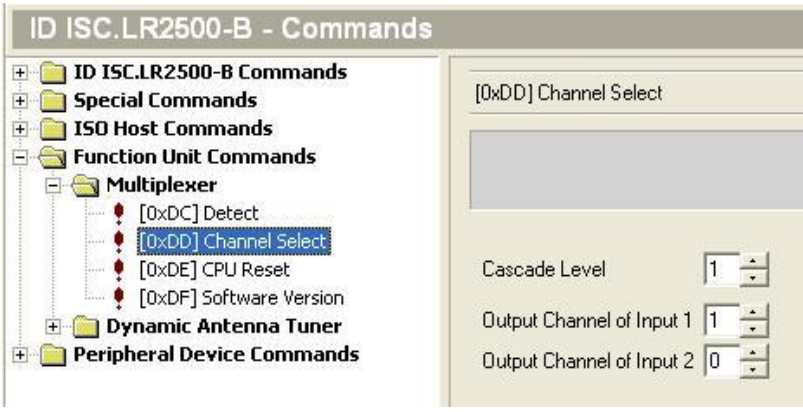
**IDENTIFICATION**

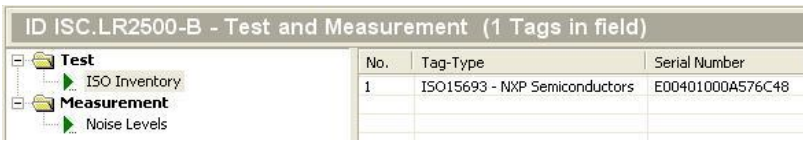
7.4.2 Reading a Serial Number

Step	Action	Note						
1	Attach a tag to an antenna In this example to antenna at multiplexer output 1	Use adhesive tape or similar.						
2	Activate antenna 1 with the command: „Function Unit Commands - Multiplexer“ Parameter: „Channel Select“ „Cascade Level = 1“ „Output Channel of Input 1 = 1“							
3	Confirm with “Send”							
4	Select „Test and Measurement“							
5	Select „ISO Inventory“ function and activate by clicking on „Start“. The serial number and tag type will be shown in the display.	 <table border="1" data-bbox="986 1120 1444 1209"> <thead> <tr> <th>No.</th> <th>Tag-Type</th> <th>Serial Number</th> </tr> </thead> <tbody> <tr> <td>1</td> <td>ISO15693 - NXP Semiconductors</td> <td>E00401000A576C48</td> </tr> </tbody> </table>	No.	Tag-Type	Serial Number	1	ISO15693 - NXP Semiconductors	E00401000A576C48
No.	Tag-Type	Serial Number						
1	ISO15693 - NXP Semiconductors	E00401000A576C48						
6	Repeat step 1 to 5 for each additional antenna.							

### 7.4.3 Testing the Performance

For testing the performance, you must switch the reader to one of the Reader Automatic Modes (see 7.6 Activating a Reader Automatic Mode).

A read transponder is indicated by a blue LED on the reader, the alarm LED light of the antenna and the alarm sounder (see also 7.5.3 Reader Setting for Alarm Indicators).

In this test, the detection area of the gate antenna, described in 7.1 Project Notes, is checked. With other tags or other configurations, the indicated ranges and detection areas may differ accordingly.

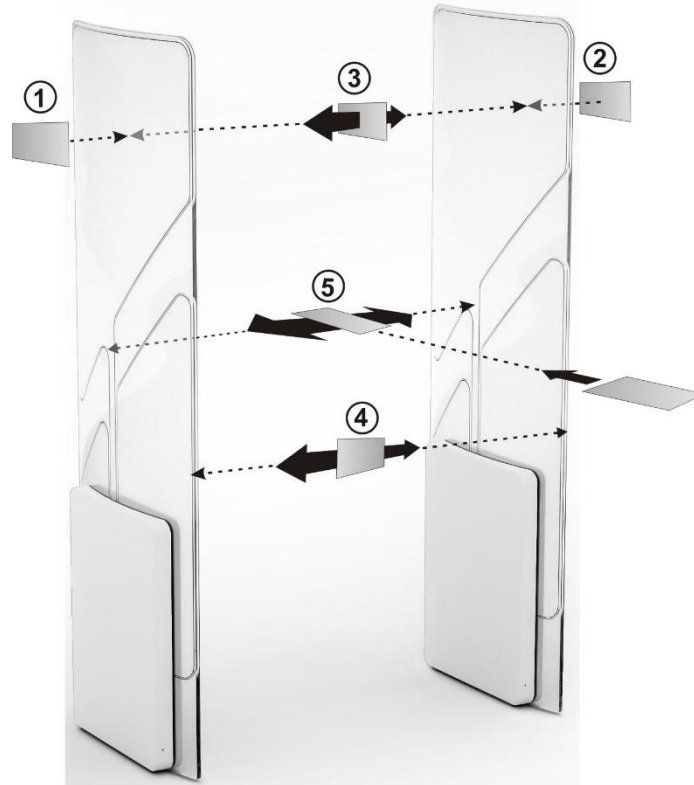

Fig. 24: Performance Test of the gate antenna

The test starts with checking the reading range outside the gate (see Fig. points ① and ②), as far as the configuration and location allow. If the tag is oriented parallel to the antenna at the outside, a reading range of 65 to 70 cm should be achieved.

The three tag orientations are checked inside the gate. This corresponds to the lines and orientations ③ ④ ⑤. Now slowly move the tag in vertical and parallel direction relative to the antenna along the line ③ from one side to the other. The tag should always be read.

Then repeat this along the line ④ in vertical tag direction transverse to the antenna and on the line ⑤ in horizontal tag orientation. The tag should always be read here as well.

The tag should be read within the gate by moving in a horizontal line through the gate in all three reading orientations.

If one or more „holes“ are detected, check the noise values on the reader (see 7.4.1 Checking the Noise Level).

## IDENTIFICATION

---

The following may result in faulty read results:

- the antenna is installed improperly (check orientation, antenna distance, cabling)
- metal near the antennas is detuning or interfering with them.
- the antennas are not properly tuned.
- the noise level is too high ( $V_{max} - V_{min} \geq 20 \text{ mV}$ )
- the transponder is too insensitive, detuned or defective
- the reader is improperly configured (transmitting power, transponder type, modulation, transponder parameters, etc.).
- a cable is defective or has a weak contact.
- reader, multiplexer or antenna are defective.

**IDENTIFICATION**

**7.5 Setting the Alarm Indicators (Alarm Buzzer and Alarm LED lights)**

**7.5.1 Setting the Alarm Buzzer**

The solution provided here presumes that the alarm indicator (buzzer) is switched through the digital output 2/X2 on the ID ISC.LRM2500-BB reader. The pulse duration can be set (CFG2/OUT2) between 100 ms and 65535 s by adjusting the reader configuration. The volume of the buzzer can be adjusted by R1.

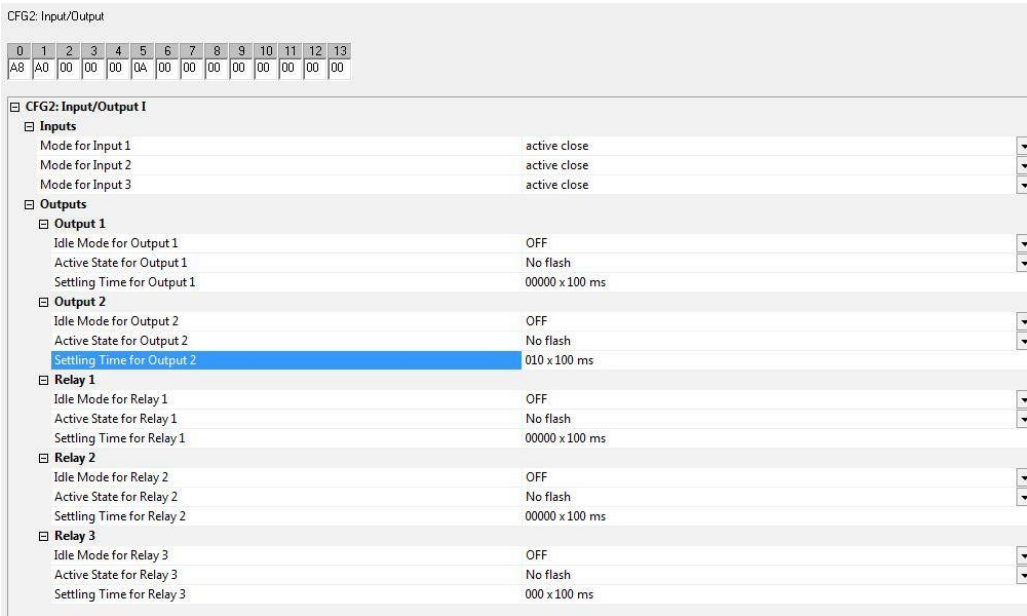

Fig. 25 Buzzer configuration

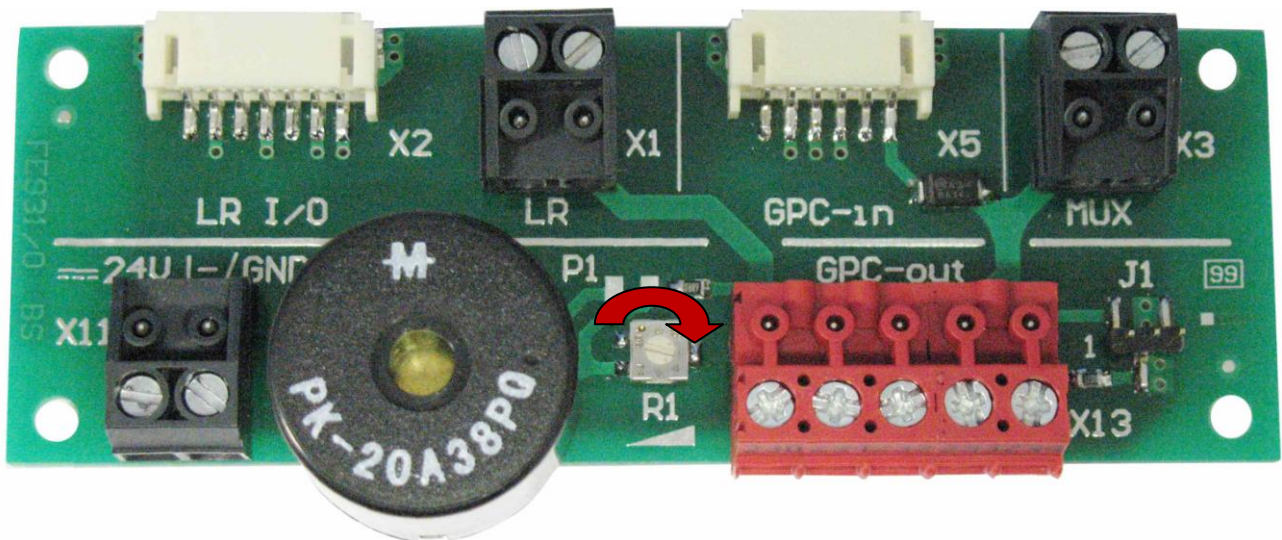

Fig. 26 Volume adjusting

### 7.5.2 Setting the LEDs

The alarm LEDs are switched via the RS485 bus by a command from the reader. For this reason, the terminal boards of all antennas used must be connected 1:1 in parallel. The Bus address for each LED is defined by the antenna number it is installed in. The antenna number depends on the output of the multiplexer the antenna is connected to.

The bus address is automatically set after the complete gate system has been set up and configured and a [0x64] System Reset command has been executed in one of the Reader Automatic Modes (see also 7.7 Automatic Bus Addressing).

The successful detection of the connected LEDs can be checked with the command [0x66] Get Reader Info.

The number of detected LEDs and their firmware version are also displayed in the LCD display after a power up or the command [0x64] System Reset.

LED in Antenna No.	Connected to Multiplexer Output No.	Bus Address No.
1	1+2	11
2	3+4	12
3	5+6	13
4	7+8	14



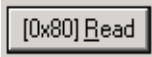
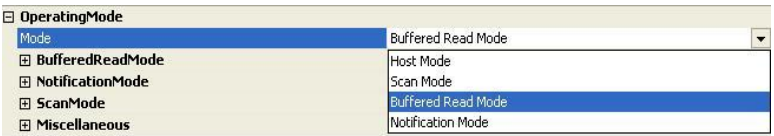
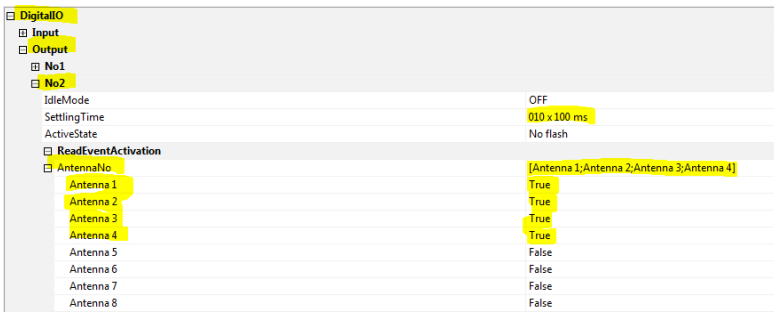

Table 9: LED overview



**IDENTIFICATION**

**7.5.3 Reader Setting for Alarm Indicators**

The ISOStart software can be used to set the reader configuration so that the output 2 X6-1/-2 opens or closes or the outputs of the people counter closes when a transponder is read.

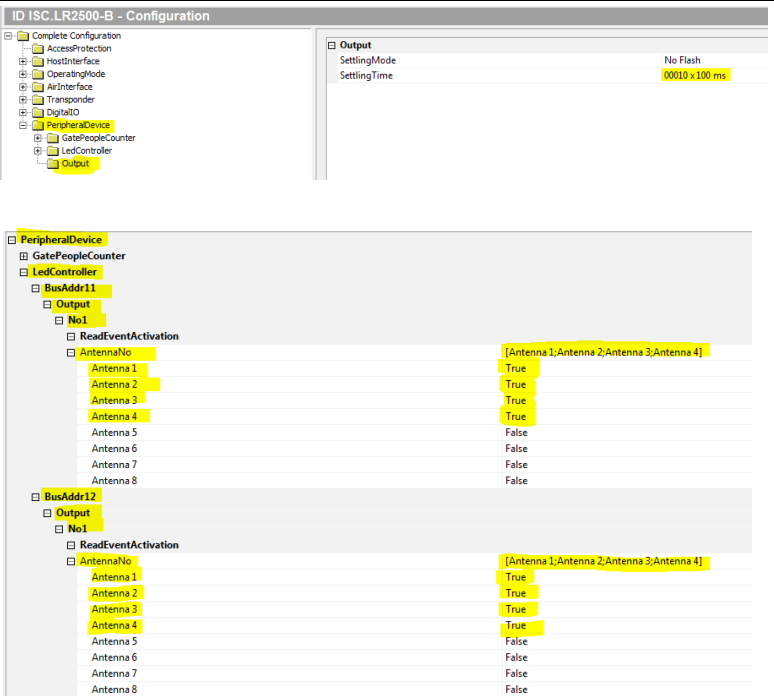
Step	Action	Note
1	Start ISOStart Software	
2	Select "Configuration" and click on "Read" to read the complete configuration.	 
3	<b>Operating Mode</b> Select Buffered Read Mode.	
4	<b>Digital IO:</b>  Idle Mode: OFF Idle Flash Mode: 1Hz Setting Time: with „Setting Time“ set time of output 2 for alarm duration. (10 means 1 second) (e.g. 10 x 100ms) Assign Output 2 to antenna 1,2,3 and 4. „True“ means: Output 2 and will be active if the reader read a valid transponder.	
5	Set by clicking on „Apply“.	
6	<b>Peripheral Device LED Controller:</b>  Setting Time: „Setting Time“ set the duration time for the alarm. (10 means 1 second) (e.g. 10 x 100ms)  Assign LEDController Bus Address 11 to antenna 1-4. LEDController Bus Address 12 to antenna 1-4. ..... and so on.  „True“ means: LED with Bus Address 11, 12, 13, 14 will be active if the reader read a valid transponder on the corresponding antenna	

**IDENTIFICATION**

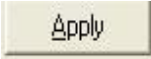
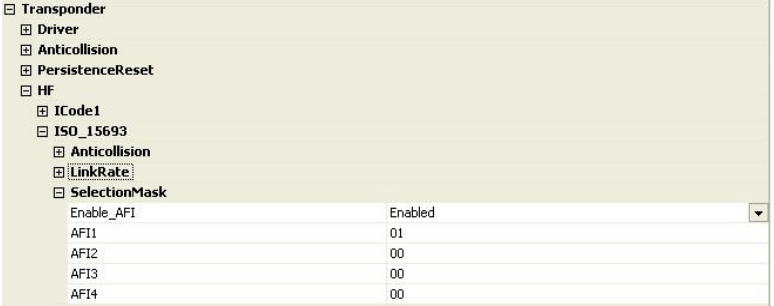
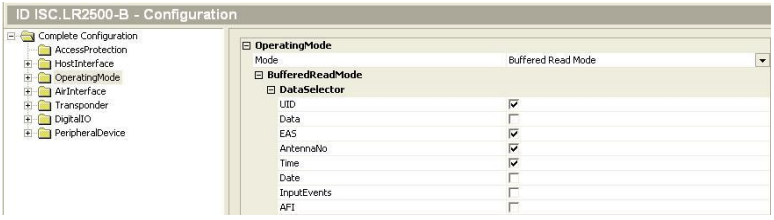
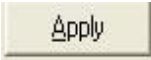

Step	Action	Note																		
7	Set by clicking on „Apply“.																			
8	<p><b>Transponder</b></p> <p>If the alarm should occur by a transponder with valid AFI byte, you have to configure the reader as follow:</p> <p>ISO-15693 – Selection Mask Set “Enable AFI”</p> <p>Set the value for the AFI in field “AFI1” (e.g. 01)</p> <p>Note: Up to four different AFI values could be set.</p>	 <table border="1"> <thead> <tr> <th>Enable_AFI</th> <th>Enabled</th> </tr> </thead> <tbody> <tr> <td>AFI1</td> <td>01</td> </tr> <tr> <td>AFI2</td> <td>00</td> </tr> <tr> <td>AFI3</td> <td>00</td> </tr> <tr> <td>AFI4</td> <td>00</td> </tr> </tbody> </table>	Enable_AFI	Enabled	AFI1	01	AFI2	00	AFI3	00	AFI4	00								
Enable_AFI	Enabled																			
AFI1	01																			
AFI2	00																			
AFI3	00																			
AFI4	00																			
9	<p><b>Operating Mode</b></p> <p>If the alarm should occur by an EAS, you have to configure the reader as follow:</p> <p>Set “EAS”</p>	 <table border="1"> <thead> <tr> <th>DataSelector</th> <th>Enabled</th> </tr> </thead> <tbody> <tr> <td>UID</td> <td><input checked="" type="checkbox"/></td> </tr> <tr> <td>Data</td> <td><input type="checkbox"/></td> </tr> <tr> <td>EAS</td> <td><input checked="" type="checkbox"/></td> </tr> <tr> <td>AntennaNo</td> <td><input checked="" type="checkbox"/></td> </tr> <tr> <td>Time</td> <td><input type="checkbox"/></td> </tr> <tr> <td>Date</td> <td><input type="checkbox"/></td> </tr> <tr> <td>InputEvents</td> <td><input type="checkbox"/></td> </tr> <tr> <td>AFI</td> <td><input type="checkbox"/></td> </tr> </tbody> </table>	DataSelector	Enabled	UID	<input checked="" type="checkbox"/>	Data	<input type="checkbox"/>	EAS	<input checked="" type="checkbox"/>	AntennaNo	<input checked="" type="checkbox"/>	Time	<input type="checkbox"/>	Date	<input type="checkbox"/>	InputEvents	<input type="checkbox"/>	AFI	<input type="checkbox"/>
DataSelector	Enabled																			
UID	<input checked="" type="checkbox"/>																			
Data	<input type="checkbox"/>																			
EAS	<input checked="" type="checkbox"/>																			
AntennaNo	<input checked="" type="checkbox"/>																			
Time	<input type="checkbox"/>																			
Date	<input type="checkbox"/>																			
InputEvents	<input type="checkbox"/>																			
AFI	<input type="checkbox"/>																			
10	Set by clicking on „Apply“																			

**IDENTIFICATION**

**7.5.4 Programming a Transponder with the AFI Byte**

If the transponders will remain on the object when leaving the storage location, they must first be disabled. This is generally done by writing to a particular area of the transponder.

The AFI byte (Application Family Identifier) is useful for this purpose as it is included in nearly all transponder models of the ISO 15693 family. To disable the transponder, simply write a different code to it than for valid transponders that trigger an alarm.

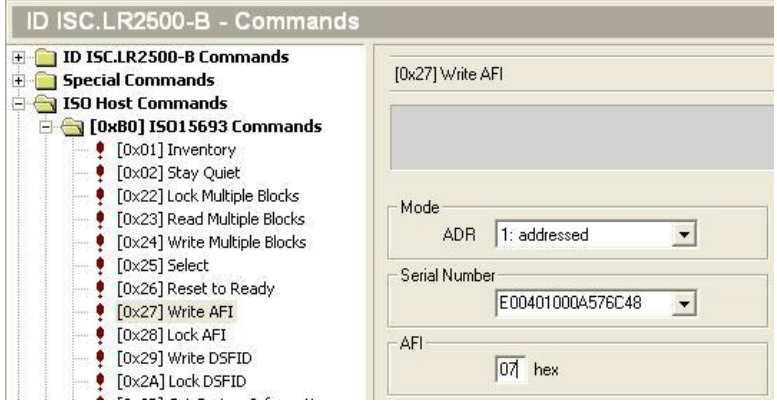
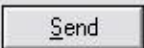
Step	Action:	Note:
1	Select „Commands“	
2	Place the Transponder in the antenna field (Antenna 1) Select [0x01] Inventory Mode: “New Inventory Requested“	
3	Read UID by clicking on „Send“	
4	The serial number, DSFID and Transponder Type HPDAre displayed in a window. Write down the serial number of the Transponder	<pre>[0xB0] [0x01] Read Serial Number Statusbyte: 0x00 (OK) 1 Transponder in Protocol 1. Transponder TR-TYPE.....: 0x03 (ISO15693 - Philips Semiconductors) DSFID.....: 0x00 SNR.....: E00401000003165C</pre>
5	Select „[0x27] Write AFI“ ADR: 1: addressed Serial Number: Select Transponder UID AFI: Desired AFI Number (not equal to 00)	
6	Write AFI byte on to the transponder by click on „Send“	

## 7.6 Activating a Reader Automatic Mode



Which mode is most suitable for your application must be defined in advance.

This example describes how to activate the Buffered Read Mode.

In the Reader Automatic Modes, the tags are read at maximum speed and the information is stored in the reader's ring buffer. The data set can be read by the host.

Due to the automatic alarm functions in the automatic mode, the reader/gate can also be operated without any interface connection (Serial, Ethernet).

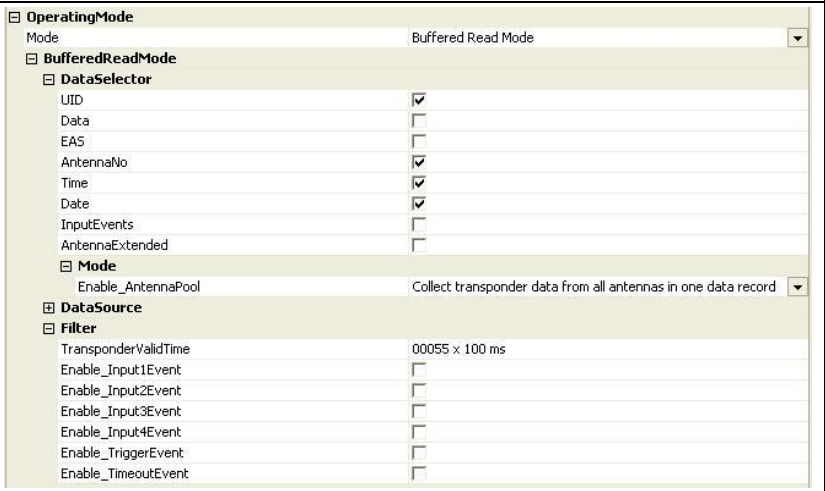
To activate the Buffered Read Mode, proceed as follows:

Step	Action	Note
1	Select „Configuration“	
2	<p><b>Operation Mode:</b> „Mode“ - Buffered Read Mode „Data Selector“ -UID -Antenna No -Time -Date</p> <p>„Filter“ Set Transponder Valid Time. (e.g. 55 x 100ms)</p>	
3	Set clicking on „Apply“	

**NOTE:**



- **The gate has to be used in one of the Automatic Modes (Buffered Read, Notification or Scan Mode) to get a maximum performance. Otherwise the reading performance will be significantly reduced.**
- **The configuration of the Notification Mode or Scan Mode are similar (see Manual of the reader). To test the function of the gate in the Buffered Read Mode, the BRM window of ISO-Start can be used.**

For more information, refer to Manual H01112-2e-ID-B.pdf ID ISC.LRM2500-A/B

**IDENTIFICATION**

**7.7 Automatic Bus Addressing**

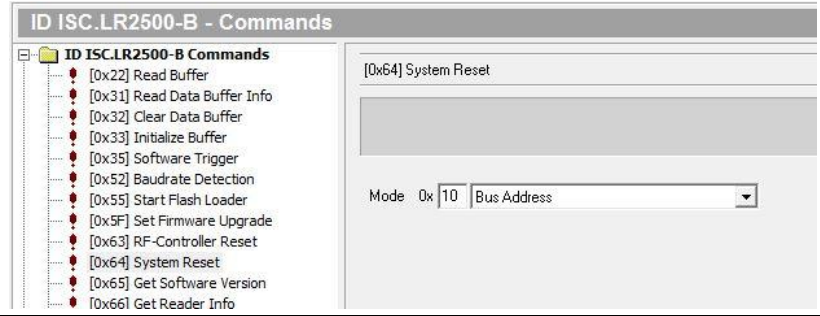
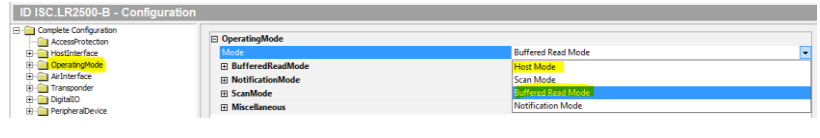
The automatic bus addressing should be done after the setup, configuration and tuning of the gate antennas. The automatic bus addressing is carried out according to the following conditions:

Step	Action	Note
1	Send a command [0x64] System Reset Mode 0x10 Bus Address in one of the automatic modes	
2	Changing the operation mode from ISO-Host to Buffered Read or Notification Mode	
3	Changing the number of output channels of the multiplexer if reader is in one of the automatic modes.	

After the automatic bus addressing the right addressing will be signaled by the LED of the antennas

- Only LED installed. The LED on the corresponding antenna lights up red. (Should be number 2 and 3)
- LED and GPC installed. The LED on the corresponding antenna lights up green. (Should be number 1 and 4) GPC must be installed in antenna number 4, otherwise the automatic bus addressing will fail!
- You might also want to check if the antennas are connected to the right output of the multiplexer.

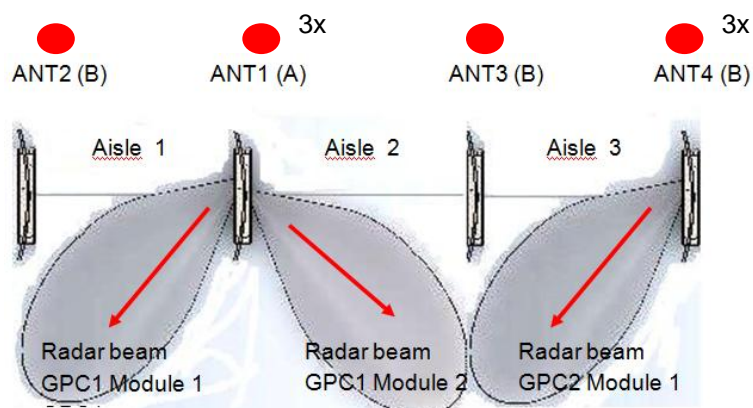

**IDENTIFICATION**

**8 Installation Gate People Counter ID ISC.ANT.GPC in Antenna No.4 Type B**

**8.1 Installation ID ISC.ANT.GPC-E2**

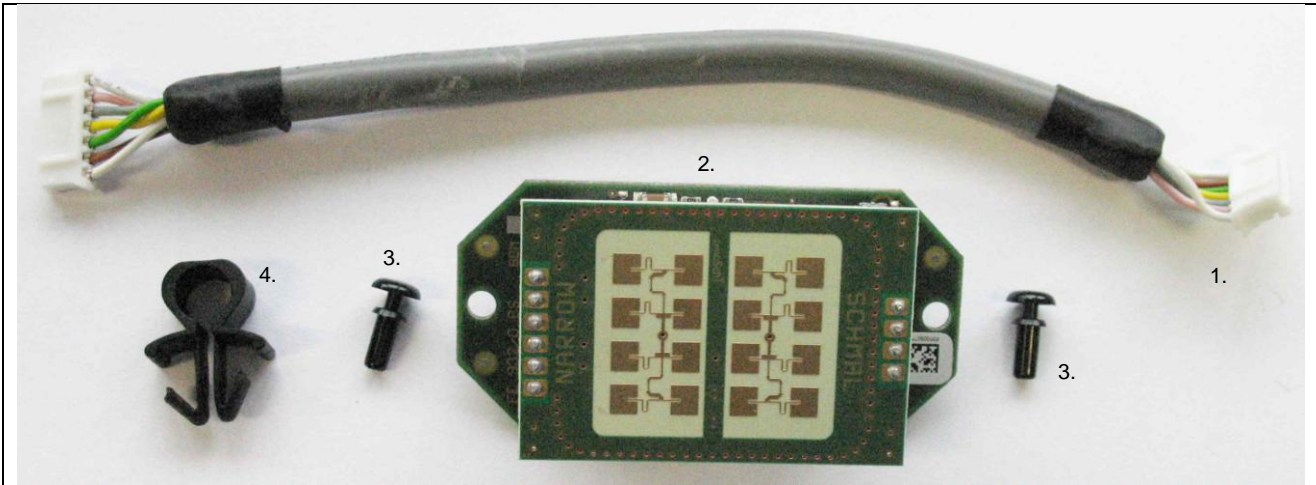

Content of the ID ISC.ANT.GPC-E2	<ul style="list-style-type: none"> <li>1. 1 piece radar connection cable</li> <li>2. 1 piece radar module</li> <li>3. 2 piece split rivet 3,0mm</li> <li>4. 1 piece cable-clip</li> </ul>
----------------------------------	---

Step	Action	Note
1.	<p>Attention!</p> <p>Note: Do not touch the antenna surface of the radar module to avoid damaging the electronic components and soiling.</p>	
2.	<p>Connect radar connection cable with X1 of radar module.</p>	

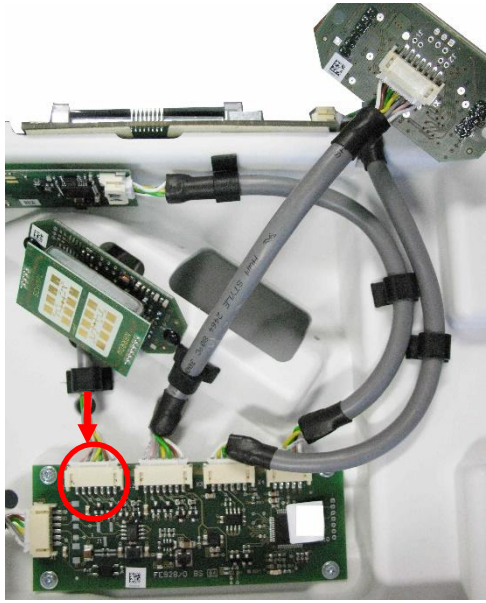
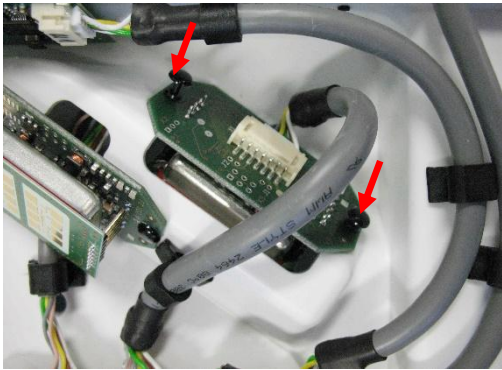

**IDENTIFICATION**

<p>3.</p>	<p>Plug radar connection cable into X12 Sen 2 and fix the cable with the cable clip.</p>	
<p>4.</p>	<p>Install radar module with split rivet.</p>	
<p>5.</p>	<p>The sensitivity of the radar module must be set after the installation with a command.</p>	<p>To check/set the sensitivity see also <a href="#">8.3.2 Configuration and Test in ISO Host Mode or Buffered Read Mode</a>, Step 8.</p>

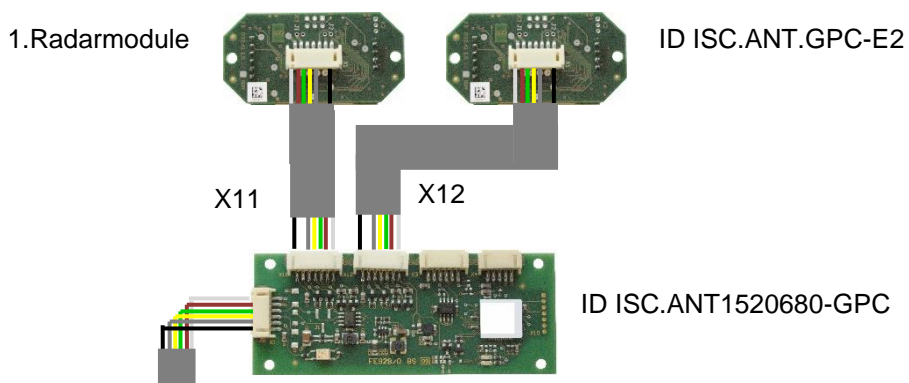
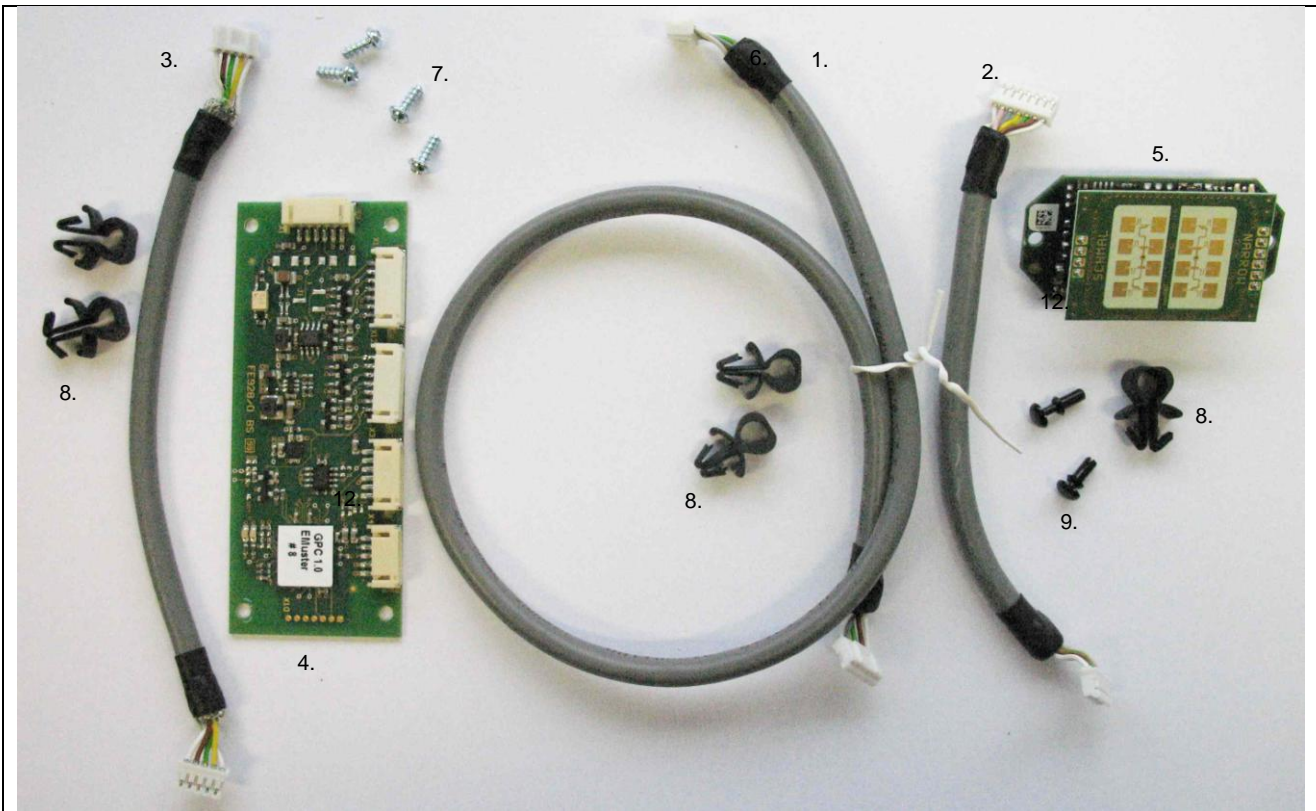

Fig. 27: Connections GPC-E 2.Radarmodule



**IDENTIFICATION**

**8.2 Installation and Connections**



Contents of the ID ISC.ANT.GPC

1. 1 piece connection cable people counter – terminal board
2. 1 piece radar connection cable
3. 1 piece LED connection cable
4. 1 piece People Counter Board
5. 1 piece radar module
6. 1 piece cable tie
7. 4 piece screw for plastic 3x12mm
8. 5 piece cable-clip
9. 2 piece split rivet 3,0mm
10. 1 piece FCC / IC Label

**IDENTIFICATION**

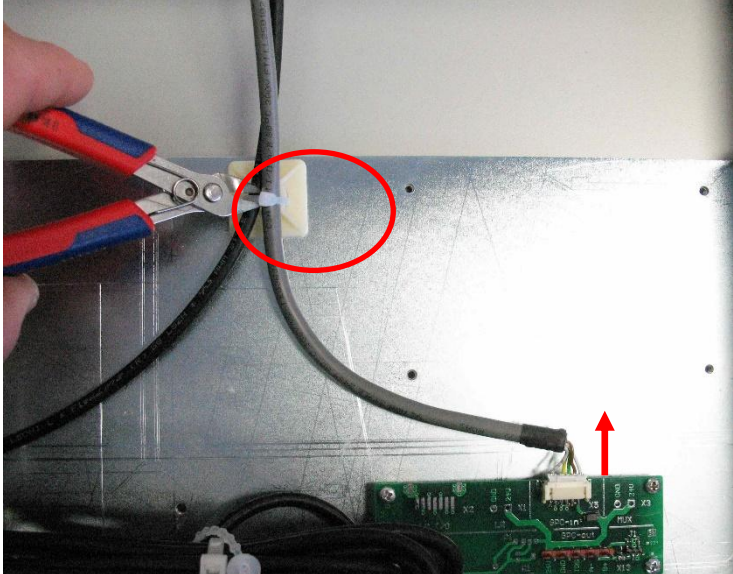
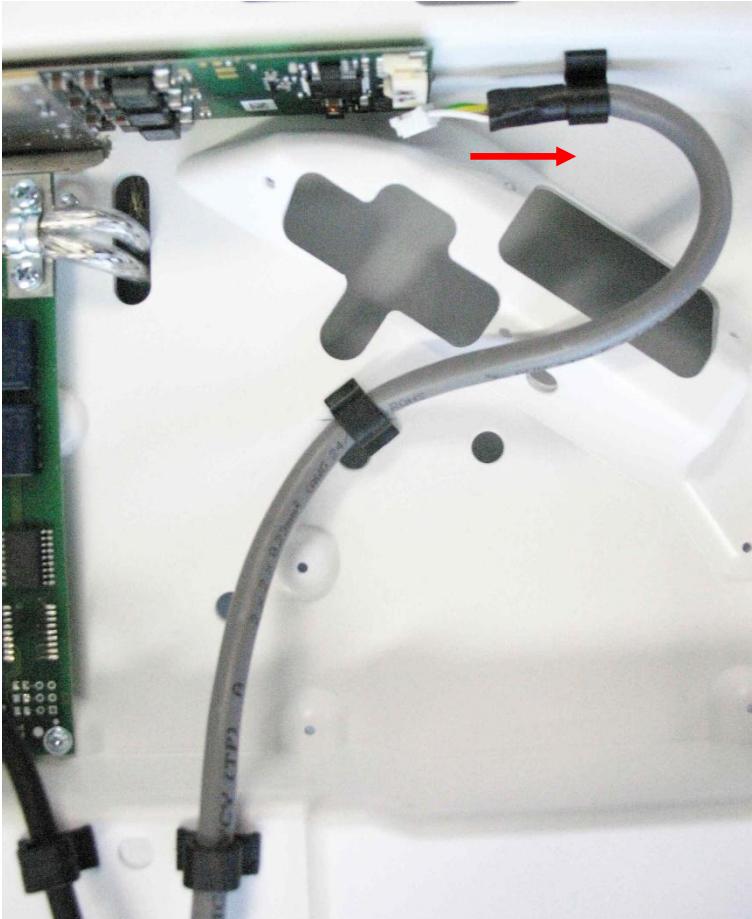
Step	Action	Note
1	Disconnect LED connection cable at the terminal board and cut the cable tie in the antenna foot.	
2	Disconnect LED connection cable at LED controller.	

**IDENTIFICATION**

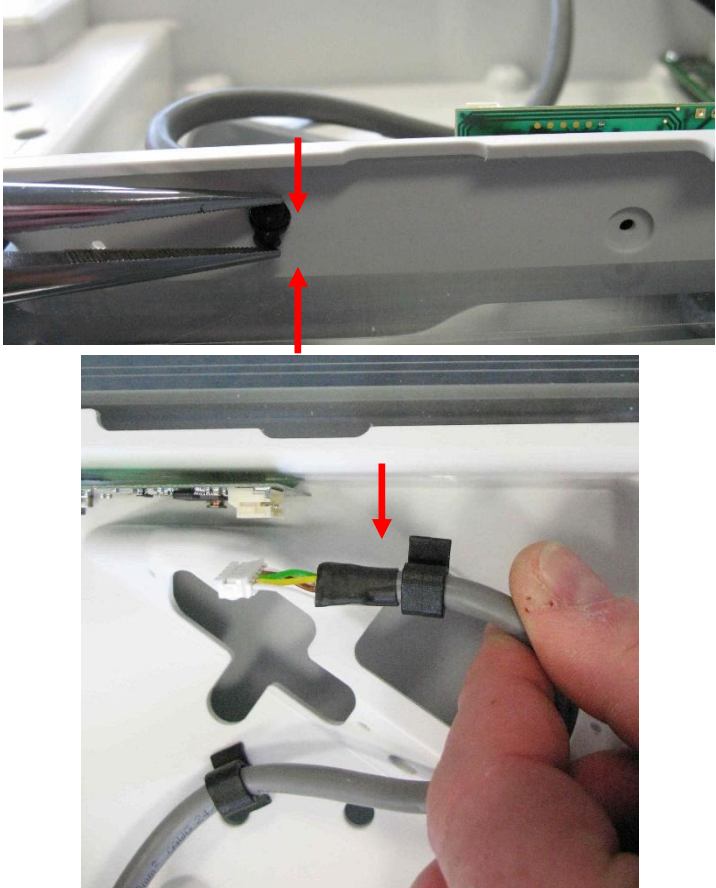
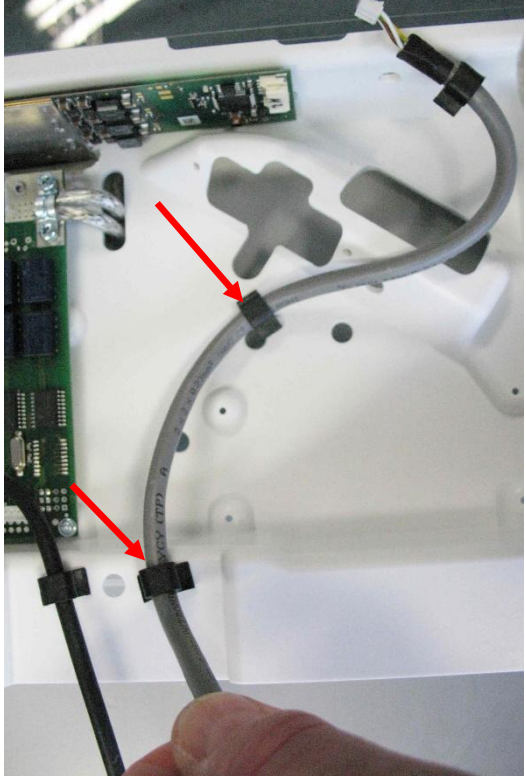

<p>3</p> <p>Remove the cable clip beside the LED controller.</p>	
<p>4</p> <p>Remove the 2 other cable clips by pulling them out with the cable.</p>	



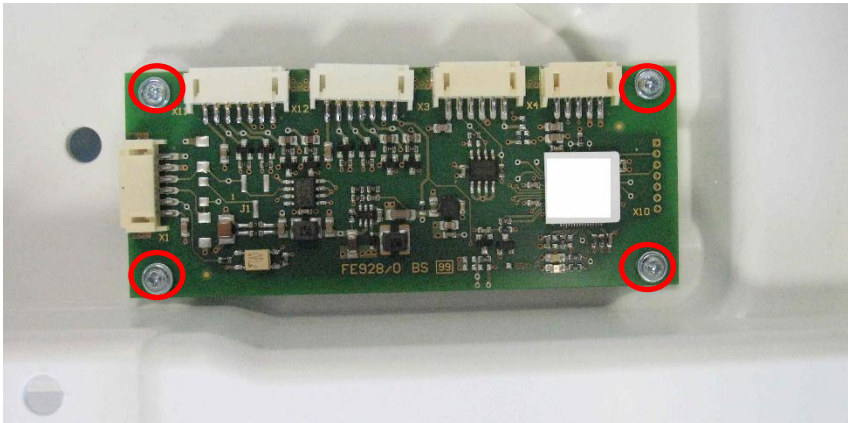
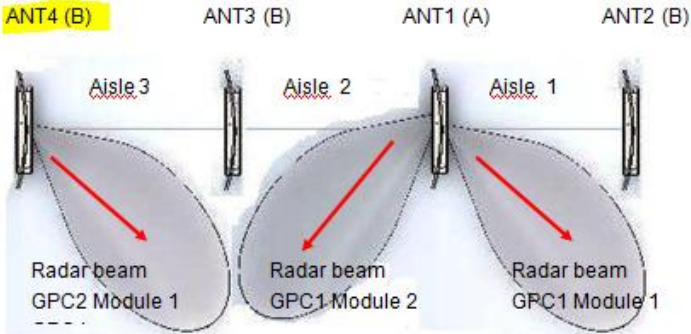
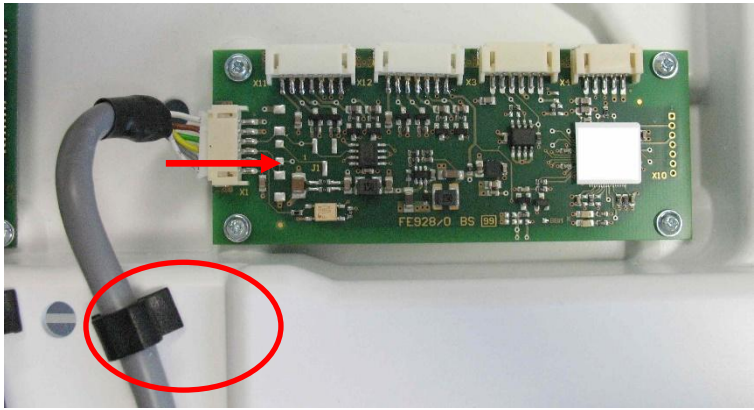

**IDENTIFICATION**

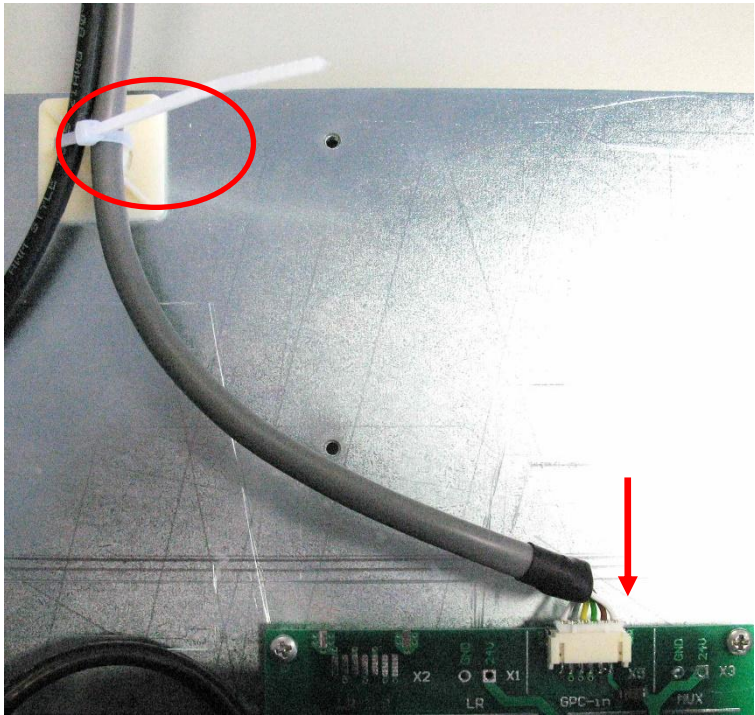
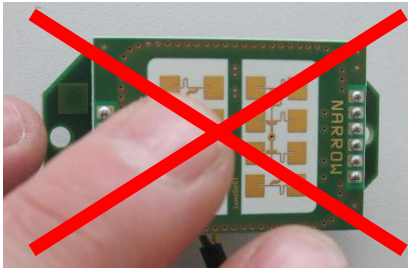
<p>5</p>	<p>Install People Counter Board into antenna with screws for plastic in antenna No.4</p> <p><b>The 2.GPC must be installed in antenna No.4 otherwise the Automatic Bus Addressing will fail !</b></p>	 
<p>6</p>	<p>Plug GPC connection cable onto X1 at GPC and X5 GPC-in at terminal board and fix it with two cable clips and the cable tie.</p>	

**IDENTIFICATION**

		
<p>7</p>	<p>Attention !! Note: Do not touch the antenna surface of the Radar module to avoid damaging the electronic components and soiling.</p>	
<p>8</p>	<p>Connect radar connection cable with X1 of Radar module.</p>	
<p>9</p>	<p>Plug Radar connection cable onto X11 Sen 1 at GPC and fix the cable with the cable clip.</p>	

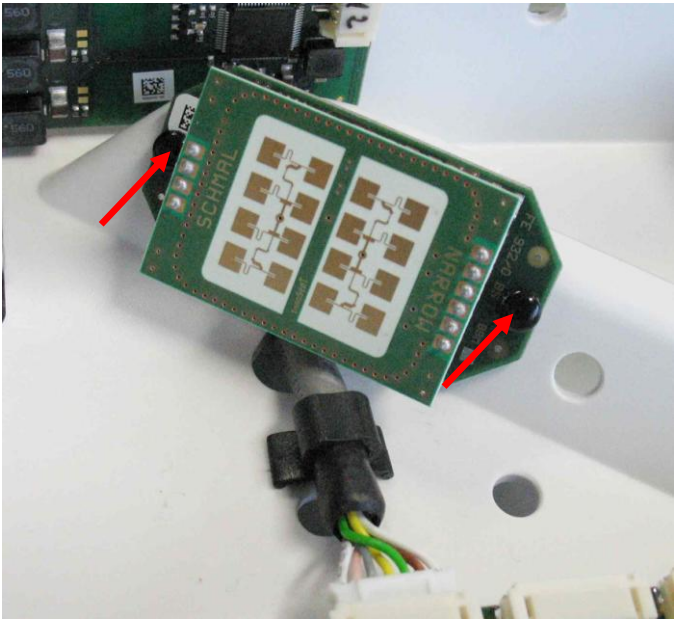
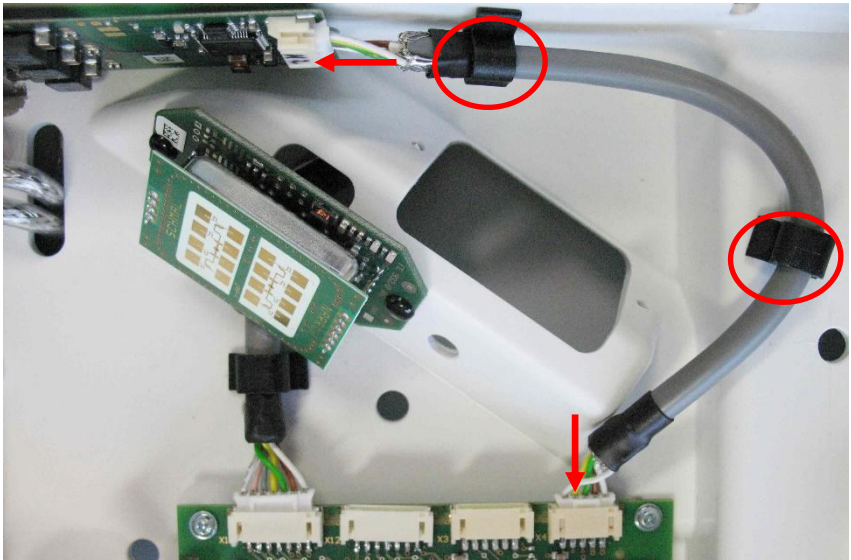
**IDENTIFICATION**

<p>10</p>	<p>Install Radar module with split rivet. Use installation hole that radar module surface faces between the antennas.</p>	
<p>11</p>	<p>The sensitivity of the radar module must be set after the installation with a command.</p>	<p>To check/set the sensitivity see also <a href="#">8.3.2 Configuration and Test in ISO Host Mode or Buffered Read Mode</a>, Step 8.</p>
<p>12</p>	<p>Connect LED cable with X1 of LED controller and fix it with the cable clips. Connect the LED cable with X3 of GPC</p>	
<p>13</p>	<p>Close antenna with antenna cover with display window After the installation you have to stick the adhesive label of the GPC below the type plate of the antenna.</p>	 <div data-bbox="1062 1688 1469 1895" style="border: 1px solid black; padding: 5px;"> <p><b>contains TX-Module with IC: 6633A-GPC and FCC ID: UXS-IPS154US</b></p> </div>
<p>14</p>	<p>The detection of the 2.and 3. GPC will be automatically done after power up the gate system or the command "System Reset" in <b>one</b></p>	



	<p><b>of the Automatic Modes.</b></p> <p>The successful detection could be checked with the command “Get reader Info” “Read All”</p>	
--	--	--

### 8.3 Configuration and Test

To activate the people counter the following settings have to be made.

In addition, set the jumpers JP10 and J11 of the reader ID ISC.LRM2500-B to configure the RS485 interface (see also Manual M81010-xe-ID-B, page 19 and 20). The Termination must be activated via software in the reader configuration.

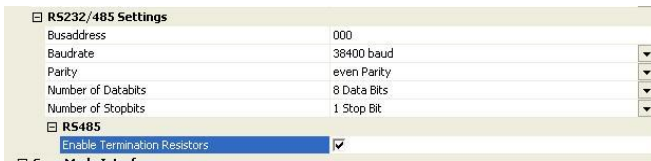
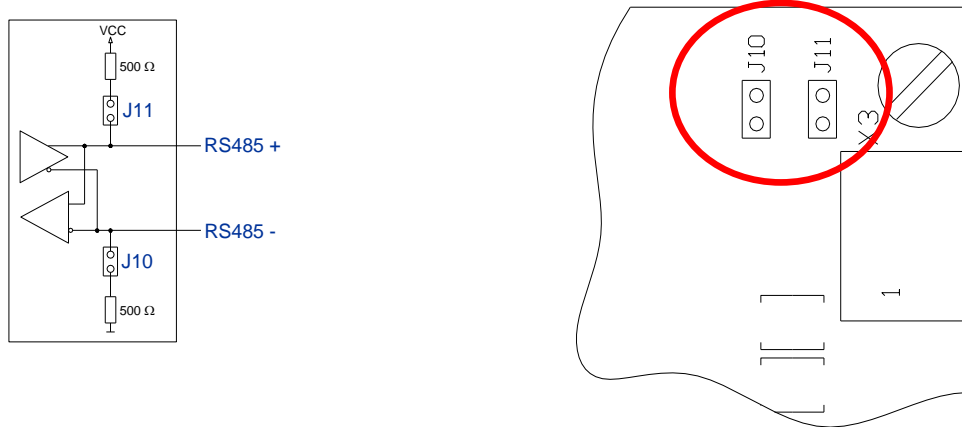

Fig. 28: Jumper settings RS485 Interface

#### 8.3.1 Connecting Several People Counters

When using several people counters (up to 3) on one reader, you must connect the terminal boards of all antennas used in parallel. A 5 (6) pin shielded, twisted-pair cable must be used for connection. Example: LiYCY (TP) 3x2x0,25 . The cable is content of antenna Type B

The bus address of the people counter will be defined by the antenna number it is installed in.

GPC1 in Antenna No.1 = Bus address No. 1

GPC2 in antenna No.4 = Bus address No. 2







The bus address is automatically set after the complete gate has been set up and configured and a [0x64] System Reset command in one of the Reader Automatic Modes has been executed.

See also 7.7 Automatic Bus Addressing. The successful detection of the connected Gate People Counter can be checked with command [0x66] Get Reader Info.

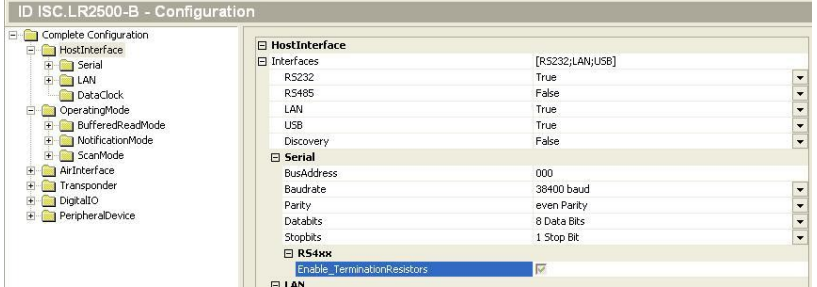

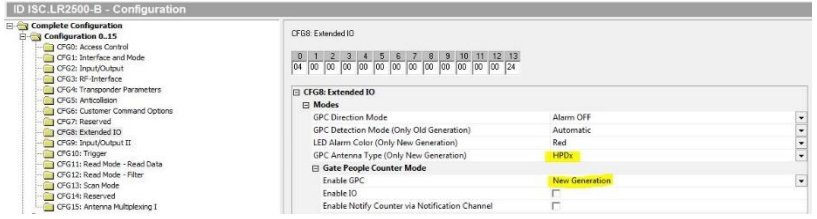

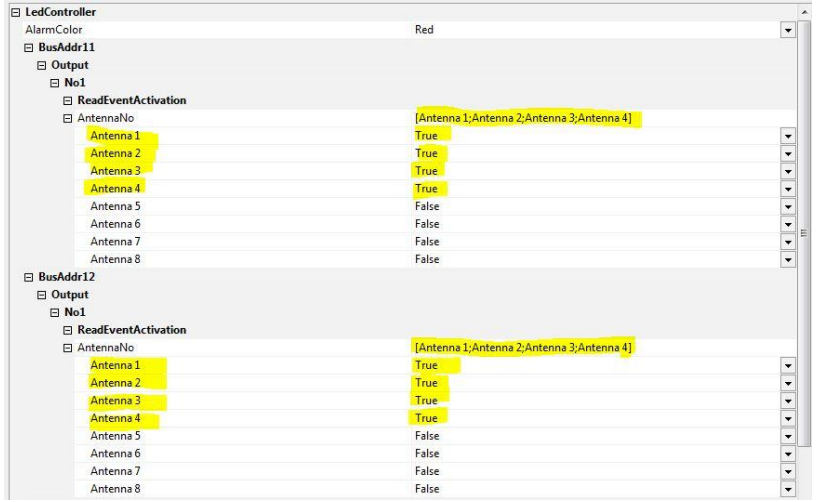

The number of detected GPC and its firmware version is also shown on the LCD display after a power-up or the command [0x64] System Reset.



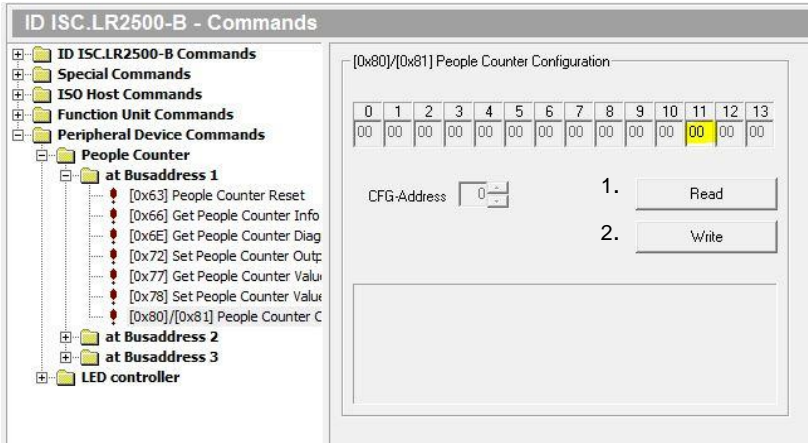



8.3.2 Configuration and Test in ISO Host Mode or Buffered Read Mode

Step	Action	Note
1	Select „Configuration“	
2	<p><b>Host Interface</b> Set RS 485 to “False” and „Enable Termination Resistors“</p> <p>The RS232/485 Settings should be set to: Busaddress=0, Baudrate=38400 baud, Parity = even , Number of Databits = 8, Number of Stopbits = 1</p>	
3	Confirm with „Apply“	
4	<p><b>Peripheral Devices Gate People Counter Mode</b> Set Antenna Type “HPDx”</p> <p>Enable GPC to „New Generation”</p>	
5	Confirm with „Apply“	
6	<p><b>Peripheral Device LED Controller:</b> Setting Time: „Setting Time“ set the duration time for the alarm. (10 means 1 second) (e.g. 10 x 100ms)</p> <p>Assign LED Bus Address 11 to antenna 1-4. LED Bus Address 12 to antenna 1-4. ..... and so on.</p> <p>„True“ means: LED with Bus Address 11, 12, 13, 14 will be active if the reader read a valid transponder on the corresponding antenna</p>	
7	Set by clicking on „Apply“.	

**IDENTIFICATION**

<p style="text-align: center; font-weight: bold; font-size: 24px;">8</p>	<p>The sensitivity of the connected radar modules could be set in</p> <p><b>-Peripheral Device Commands</b></p> <p><b>-People Counter</b></p> <p><b>-at Busaddress 1 and 2</b></p> <p>-Byte 11:</p> <p>00 = Low 05 = Middle 0A = High <b>0F = Very high (Default)</b></p> <p>First “Read” out actual setting of sensitivity.</p> <p>If needed change to new sensitivity by “Write” the new value into the GPC.</p> <p>A “People Counter Reset” command must be sent to confirm the change, otherwise the sensitivity will not change.</p>	 
<b>Test: People Counter</b>		
<p style="text-align: center; font-weight: bold; font-size: 24px;">9</p>	<p>Select „Commands“</p>	
<p style="text-align: center; font-weight: bold; font-size: 24px;">10</p>	<p>Select Command - „Get Reader Info“ Peripheral Devices</p>	
<p style="text-align: center; font-weight: bold; font-size: 24px;">11</p>	<p>Confirm with „Send“ Number of Devices should be 1</p>	
<p style="text-align: center; font-weight: bold; font-size: 24px;">12</p>	<p>Select Command „Set People Counter Values“</p>	
<p style="text-align: center; font-weight: bold; font-size: 24px;">13</p>	<p>Confirm with „Send“</p>	

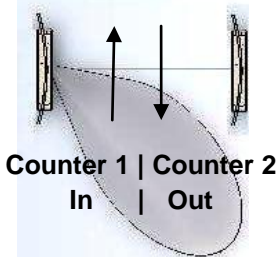
**IDENTIFICATION**

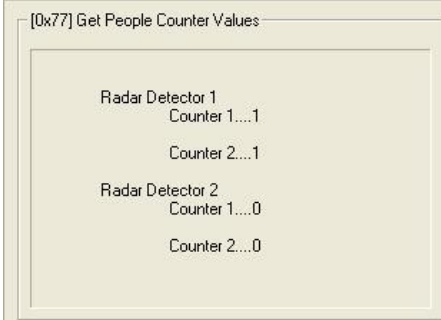
<p>13</p>	<p>Select Command „Get People Counter Values“</p>	
<p>14</p>	<p>Confirm with „Send“ All counter values should be 0</p>	
<p>15</p>	<p>Walk through the gate from both directions.</p>	
<p>16</p>	<p>Select Command „Get People Counter Values“</p>	
<p>17</p>	<p>Confirm with „Send“</p>	
<p>18</p>	<p>Counter values will be displayed.</p>	

In ISO Host Mode and Buffered Read Mode the people counter must be polled by the host application to get the data. In Notification Mode the reader sends the people counter data automatically to the host.

8.3.3 Configuration and Test in Notification Mode

The following configuration has to be done:

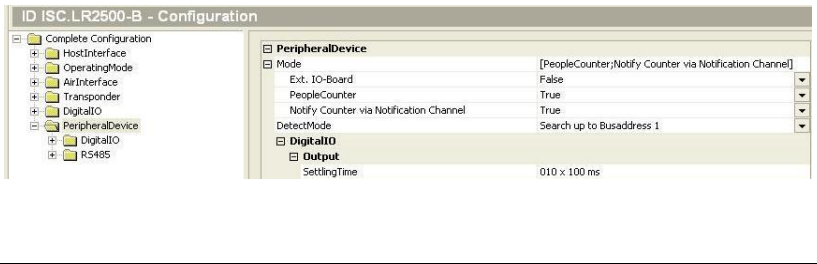
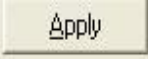
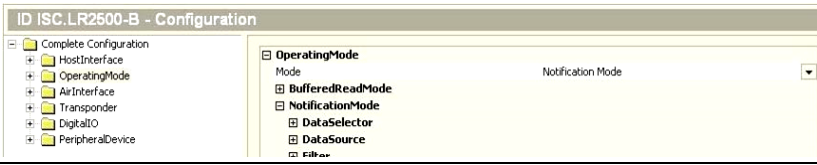
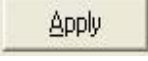
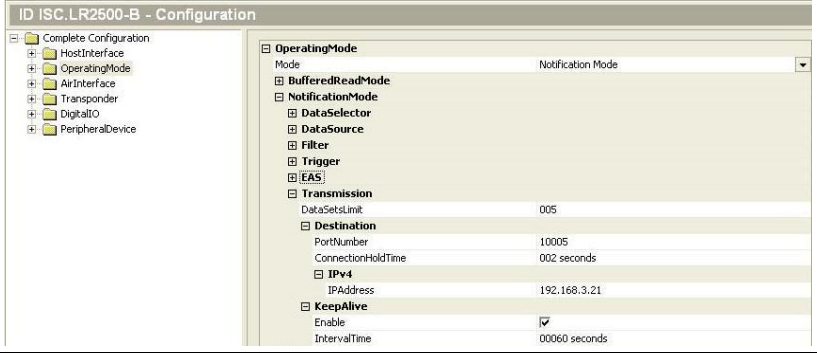
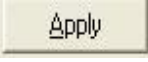
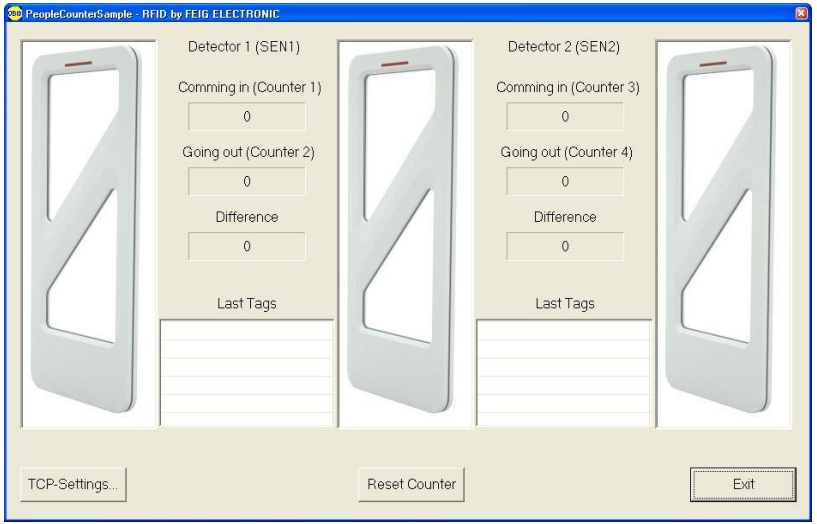
Step	Action	Note
1	Select „Configuration“	
2	<b>Peripheral Devices</b> Set People Counter and Notify Counter to „True“	
3	Confirm with „Apply“	
4	<b>Operating Mode</b> Select Notification Mode	
5	Confirm with „Apply“	
6	<b>Set IP Address and Port for Notification Mode</b> IP Address of Host e.g. here: 192.168.3.21 Port:10005 The same TCP/IP Address and Port Address is valid for the Notification Chanel of the People Counter und Notification Chanel of the data	
7	Confirm with „Apply“	
8	A Test could be done with the People Counter Sample.	

9

Therefore you will have to set both ports have the same address, at the TCP-Settings.

**TCP/IP-Settings**

Listener Port for Tag Events

Port: 10005

NOTE: Reader Parameter  
OperatingMode.NotificationMode.Transmission.Destination.PortNumber

Listener Port for Counter Events

Port: 10005

NOTE: Reader Parameter  
OperatingMode.NotificationMode.GatePeopleCounter.Transmission.Destination.PortNumber

Address and Port of Reader

IP-Address: 192 . 168 . 3 . 69      NOTE: must be defined to reset the Counter Values.

Port: 10001

NOTE: Use ISOStart to configure the Reader

OK      Abbrechen

### 8.3.4 Using the Trigger Function of the Gate People Counter

**NOTE:**

*The trigger function can only be used in one of the Reader Automatic Modes.*

The trigger function works bidirectional, but 100% reliable reading of transponders is only possible from one direction. For this reason it is necessary that the radar module/antenna faces the direction of the transponder which could trigger the alarm. In buildings (e.g. libraries) the radar module faces into the building. Otherwise the reading of the transponder is only starting when the person/transponder is already inside or outside the gate.

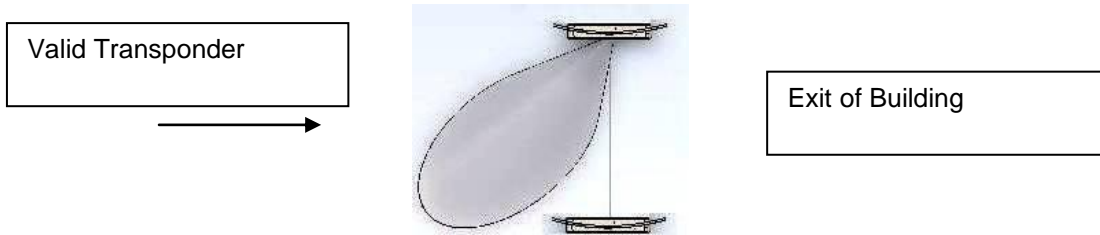

Fig. 29: Orientation of the radar module for trigger function

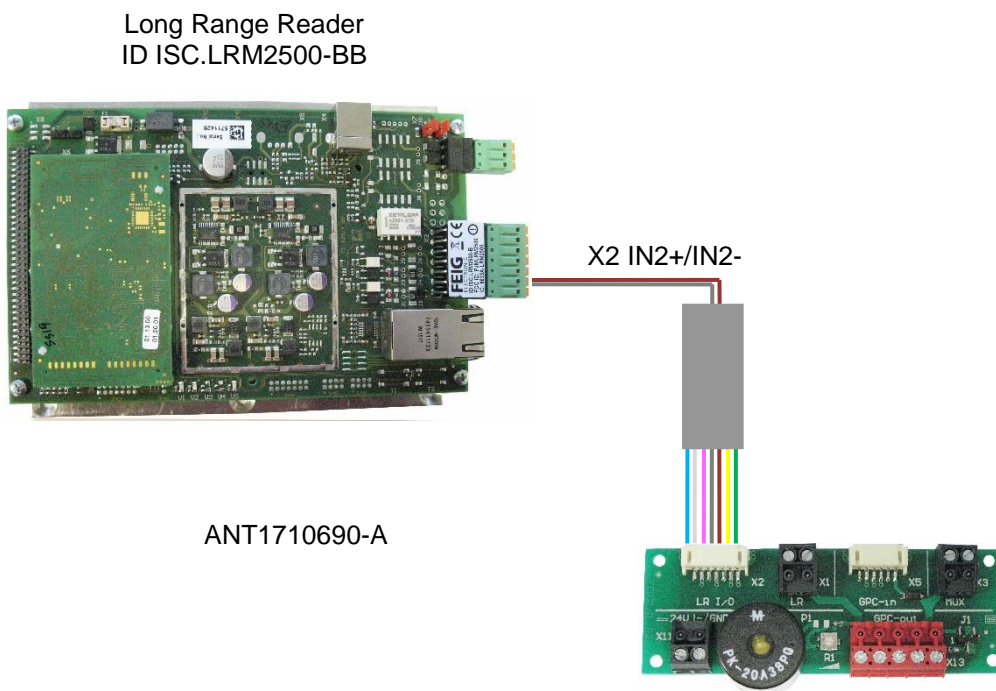

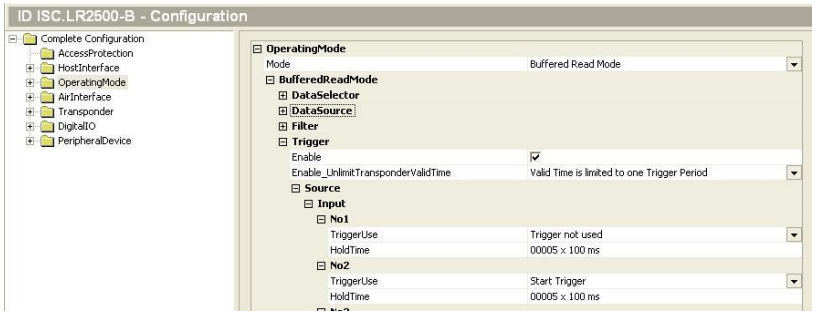

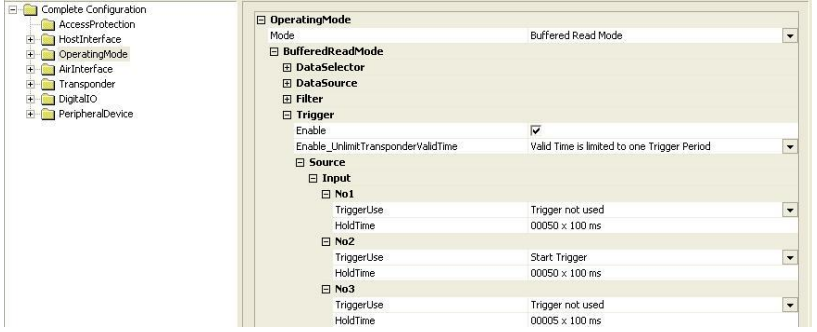

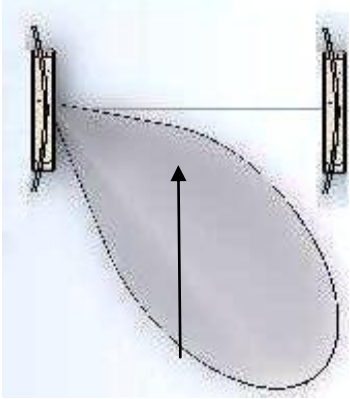

Fig. 30: Connection ID ISC.LRM2500-BB to ID ISC.ANT1710/690-A



**IDENTIFICATION**

Step	Action	Note
1	Select „Configuration“	
2	<p><b>Operating Mode</b></p> <p>Select</p> <ul style="list-style-type: none"> <li>-Buffered Read Mode</li> <li>or</li> <li>-Notification Mode</li> </ul>	
3	Confirm with „Apply“	
4	<p><b>Operating Mode</b></p> <p>Set</p> <ul style="list-style-type: none"> <li>-Trigger enable</li> <li>-Source Input No 2-Trigger TriggerUse set to</li> <li>- Start Trigger</li> <li>- Hold Time e.g. 20x100ms =2sec.</li> </ul>	
5	Confirm with „Apply“	
6	Multiplexer stops switching of antennas. All Output LED's at Outputs of Multiplexer are switched off.	
7	Walk through the gate. Multiplexer/Gate will be switch on for the set time.	





**IDENTIFICATION**

**8.3.5 Using the Direction Detection of Transponders with the Gate People Counter**

In combination with the people counter, direction detection of the transponders can be performed in such way that only those transponders trigger an alarm that move through the gate in the configured direction. This should reduce false alarms. It is possible that cross traffic in front of the antenna can still cause false alarms, if a valid transponder moves in the set direction.

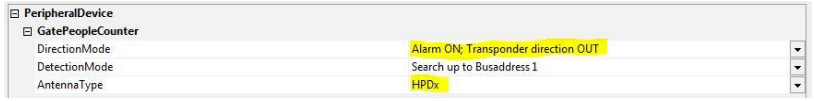
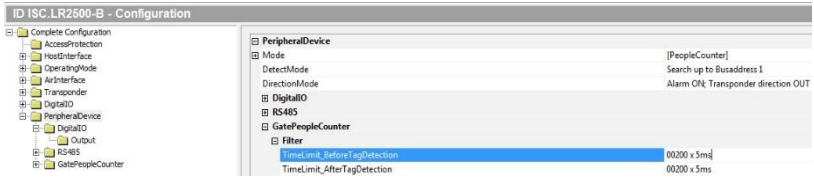
It is mandatory that the trigger cable described in 8.3.4 Using the Trigger Function of the Gate People Counter is connected to input 2 of the reader and X4/TRG of the terminal board, otherwise the direction mode will not work!

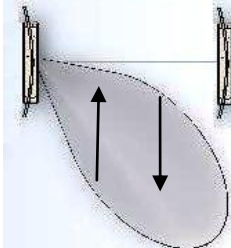
Step	Action	Note
1	Select „Configuration“	
2	<p><b>Select Peripheral Devices – Gate People Counter</b></p> <p>Set Direction Mode to the needed alarm direction.</p> <p><b>Select Perhipheral Devices - Filter</b></p> <p>Set Time Limit before and after Tag Detection. e.g. 200x5ms =1000ms</p> <p>Time should be not to short or to long!</p>	 
3	Confirm with „Apply“	
7	Walk through the gate with a valid transponder and check the alarm direction.	

If there are multiple gates with more than two antennas, the correct number order of the connected antennas, alarm LEDs and people counters with radar module must be observed. For information on setup, connection and configuration, refer to Application Note N91020-xe-ID-E.pdf.

8.3.6 Detection Area of the Direction Mode

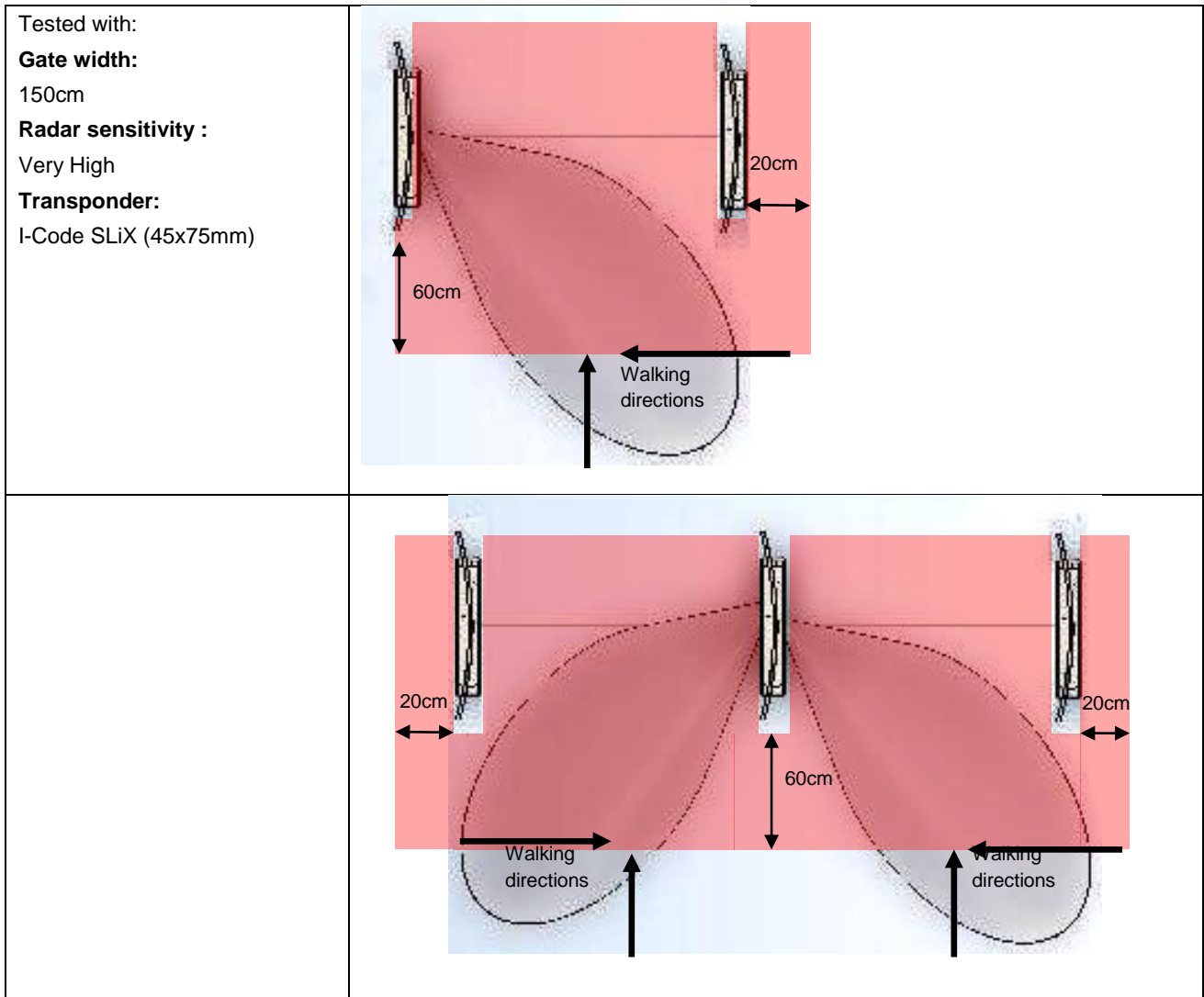

Fig. 31: Detection are of the direction mode

## 9 Reader Configuration in Accordance with National RF Regulations

Configuration of the RFID readers and the maximum transmitting power of the antennas are affected mainly by the country-specific RF regulations. For the entire EU, the limits are set forth in the R&TTE Directive and EN 300 330.

The ID ISC.ANT1710/690 antenna with the ID ISC.LRM2500 Reader, when used as intended, complies with the basic requirements of Article 3 and the other relevant clauses of the R&TTE Directive 1999/5/EG of March 1999. This means that operation in the 27 EU countries and the EFTA countries (EU countries plus Switzerland, Norway and Iceland) is possible with a maximum field strength of 42 dB $\mu$ A/m at 10 m distance.

RF approval (at a maximum field strength of 84 dB $\mu$ V/m at 30 m) for the ID ISC.ANT1710/690 antenna with ID ISC.LRM2500 Reader has been granted in accordance with FCC Part 15 for the USA and the RSS-210 for Canada.

RF approval in accordance with EN 300 330 is still possible in all 46 CEPT countries.

The CEPT countries are:

Albania (ALB), Andorra (AND), Austria (AUT), Azerbaijan (AZE), Belarus (BLR), Belgium (BEL), Bulgaria (BUL), Bosnia and Herzegovina (BIH), Croatia (HRV), Cyprus (CYP), Czech Republic (CZE), Denmark (DNK), Estonia (EST), Finland (FIN), France (F), Germany (D), Greece (GRC), Hungary (HNG), Iceland (ISL), Ireland (IRL), Italy (I), Latvia (LVA), Liechtenstein (LIE), Lithuania (LTU), Luxembourg (LUX), Malta (MLT), Former Yugoslav Republic of Macedonia (MKD), Moldova (MDA), Monaco (MCO), Netherlands (HOL), Norway (NOR), Poland (POL), Portugal (POR), Romania (ROU), Russian Federation (RUS), San Marino (SMR), Slovak Republic (SVK), Slovenia (SVN), Spain (E), Sweden (S), Switzerland (SUI), Turkey (TUR), Ukraine (UKR), United Kingdom (G), Vatican City (CVA) and Yugoslavia.

The following restrictions are in effect (as of October 2009):

Outside the EU and EFTA countries RF approval must in all cases be applied for. The existing measuring protocols in accordance with EN 300 330 are generally sufficient.

When commissioning the antennas, the systems integrator must ensure that the prescribed installation instructions are followed, that the necessary reader settings are made and that permissible limits according to national regulations are not exceeded.

The reader needs to be configured as follows depending on the installation location:

Parameter	USA / Canada / Europe
<b>Air Interface</b>	
RF-Power:	maximum 4 W
RF Modulation:	15%
<b>Transponder</b>	
RF Modulation / ISO-MODE / MOD	10%
RF Data coding ISO-MODE:	Fast (1/4) or Normal (1/256)
Timeslots ISO-MODE / NO-TS	1 or 16 Timeslots
ISO Option – BREAK:	Complete Timeslot length at „NO TAG“

## 10 Technical Data

### 10.1 Antenna ID ISC.ANT1710/690 Type A and B Crystal Gate Excellence

#### MECHANICAL DATA

• Housing	• UV stabilized ABS and Acrylic
• Dimensions ( W x H x D )	
– Antenna	690 mm x 1770 mm x 72 mm ± 3 mm
– Packing	850 mm x 1920 mm x 162 mm ± 10 mm
• Weight	
– ID ISC.ANT1710/690-EA	ca. 25 kg / 31 kg without/with packing
– ID ISC.ANT1710/690-EB	ca. 23 kg / 28 kg without/with packing
• Enclosure rating	• IP 41
• Colors	
- Antenna frame	acryl glass, clear transparent
- Antenna base	signal white like RAL 9003
• Mounting	
– No. of attaching points	2
– Recommended anchors	∅ 10 mm
– Recommended minimum load capacity of the floor fastener	5000 N / anchor
• Unevenness of the acrylic plate	• ± 10 mm
• Tolerances on thickness and Quality	• ISO 7823-1
• Maximum horizontal load on the top edge of the antenna	• 250 N*

#### ELECTRICAL DATA

• Supply Voltage	• 24 V $\pm$ 15 %
• Power Consumption	• max. 70 VA
	• Stand by (Trigger function enabled) 9 VA
	• Operating (No alarm) 17 VA
	Operating (Alarm LED + Buzzer switched on) Single Gate 31,5 VA Double Gate 38,5 VA Triple gate 48,5VA
• Operating Frequency	• 13,56 MHz
• Maximum transmitting power per antenna	• 4 W
• Permissible overall transmitting power per antenna gate	
– EU-territory (per EN 300 330)	4.0 W
– USA (per. FCC Part 15)	4.0 W
- Canada (per. RSS210)	4.0 W
• Outputs	
– 1 Optocoupler	Buzzer
– 1 Optocoupler	Reader Synchronization
– 1 Relay (NO)	24 V $\pm$ / 1 A
• Inputs	
– 1 Optocoupler	Trigger
– 1 Optocoupler	Reader Synchronisation

**IDENTIFICATION**

- |  |  |
|--|--|
| • Interfaces   | • USB, Ethernet (TCP/IP)   |
| • Protocol Modes                                       | • FEIG ISO HOST<br>BRM (Data Filtering and Data Buffering)<br>Scan Mode (RS 232)<br>Notification Mode (TCP/IP)               |
| • Supported Transponders                               | • ISO 15693, ISO 18000-3-A, NXP I-Code 1   |
| • Ranges / pass-through width in gate with multiplexer | •  |
| – One tag orientation                                  | up to 200 cm**   |
| – All tag orientations                                 | up to 150 cm***  |
| • Antenna connection                                   | • 1 x SMA plug (50 Ω)  |
| • Antenna connector cable<br>- Type HPDB               | •<br>RG58, 50 Ω, approx. 8,05 m long   |
| • Alarm functions                                      | • EAS, AFI, UID/SNR<br>automatic without host connection   |
| • Alarm devices  | • Sounder (adjustable volume)<br>LED alarm light (red color)   |
| • Additional integrated features                       | • People Counter (1 aisle),<br>automatic trigger feature to avoid false alarms,<br>Standby mode to reduce energy consumption |

**ENVIRONMENTAL CONDITIONS**

- |                     |                  |
|---------------------|------------------|
| • Temperature range | •                |
| – Operating         | –25 °C to +50 °C |
| – Storage           | –25 °C to +70 °C |

**APPLICABLE STANDARDS**

- |                         |                            |
|-------------------------|----------------------------|
| • RF approval           | •                          |
| – Europe                | EN 300 330                 |
| – USA                   | FCC Part 15                |
| - Canada                | RSS 210                    |
| • EMC                   | • EN 301 489               |
| • Safety                | •                          |
| – Low Voltage Directive | UL 60950-1                 |
| – Human Exposure        | EN 50364                   |
| • Product testing       | • ISO 18046-4 / VDI-4478-1 |

\* Persistent deformation after load release approx. 3 cm.

\*\* Qty. 2 ID ISC.ANT1710/690-A/-B Crystal Gate Excellence antennas, antenna spacing (antenna center), same flow direction, Tag 46 mm x 75 mm ISO15693, sensitivity / minimum field strength  $H_{min}=40$  mA/m rms, transmitting power 4 W, tag orientation parallel to antenna for horizontal movement through the antenna. The maximum antenna distance also depending of the strength of the Transponder answer signal! Z.B NXP I-Code SLi-x2

\*\*\* Tag 46 mm x 75 mm ISO 15693, sensitivity / minimum field strength  $H_{min}=40$  mA/m rms, transmitting power 4 W, aligned in all 3 dimensions for horizontal movement through the antenna. The maximum antenna distance also depending of the strength of the Transponder answer signal! e.g. NXP I-Code SLi-X2

## 10.2 People Counter ID ISC.ANT.GPC and ID ISC.ANT.GPC-E2

### MECHANICAL DATA

- |                                  |  |
|----------------------------------|--|
| • Housing                        | • Printed Boards                         |
| • Board Dimensions ( B x H x T ) | •  |
| – People Counter Board           | 100 mm x 40 mm x 16 mm ± 1 mm            |
| – Radar Sensor Board             | 60 mm x 30mm x 25 mm ± 1 mm              |
| • Weight                         | •  |
| – ID ISC.ANT.GPC                 | ca. 200 g / 250 g (0.55 lb) with packing |
| – ID ISC.ANT.GPC-E2              | ca. 50 g / 100 g (0.22 lb) with packing  |

### ELECTRICAL DATA

- |                         |                     |
|-------------------------|---------------------|
| • Supply Voltage        | • 24 V $\pm$ 15 %   |
| • Power Consumption     | • max. 2 VA         |
| • Operating Frequency   | • 24,125 GHz        |
| • RF-transmitting power | • 16 dBm (e.i.r.p.) |
| • Outputs               | •                   |
| – 1 Optocoupler         | Trigger Reader      |
| • Temperature range     | •                   |
| – Operation             | –25 °C to +55 °C    |
| – Storage               | –25 °C to +85 °C    |

### FUNCTIONS

- |                                       |  |
|---------------------------------------|--|
| • Number of Aisles per People Counter | • 1 or 2 aisles by using the second radar module (ID ISC.ANT.GPC-E2) |
| • Extension                           | up to 3 aisle → 2. People Counter for the 3. aisle                   |
| • Direction detection                 | • Yes  |
| • Counter per aisle                   | •  |
| – 1 x direction 1 / In                | 0..4 294 967 295   |
| – 1 x direction 2 / Out               | 0..4 294 967 295   |



### 10.3 Power Supply ID ISC.NET24V-B

Is included in the packaging of the antenna ID ISC.ANT1710/690 Type A.

#### MECHANICAL DATA

- |                            |  |
|----------------------------|--|
| • Type                     | • Desktop power supply with IEC socket according IEC60320-C13, 3-pin |
| • Housing                  | • Plastic  |
| • Dimensions ( W x H x D ) | • 58 x 30,5 x 132 mm ± 1 mm<br>(2.3" x 1.2" x 5.2" ± 0.04")          |
| • Weight                   | • approx. 345 g  |
| • Enclosure rating         | • IP 41  |
| • Color                    | • Black  |

#### ELECTRICAL DATA

- |                     |                           |
|---------------------|---------------------------|
| • Supply voltage    | • 110 – 240 VAC, 50-60 Hz |
| • Output voltage    | • 24 V $\pm$ 5 %          |
| • Power consumption | • max. 3,0 A              |
| • Output power      | • max. 70 VA              |
| • Electrical safety | • EN60950, UL60950        |
| • Protection class  | • I                       |

## 11 Approvals

As per Section 9 Reader Configuration in Accordance with National RF Regulations.

### 11.1 Europe (CE)

#### 11.1.1 Antenna ID ISC.ANT1710/690 Crystal Gate Excellence

This RF equipment is in compliance with the essential requirements and other relevant provisions of Directive 2014/53/EU (RE Directive) dated 16'th of April 2014.



Equipment Classification according to ETSI EN 300 330 and ETSI EN 301 489: Class 2

**The technical data of the ID ISC.LRM2500-BB reader built into the ID ISC.ANT1710/690-A Crystal Gate Excellence antenna can be found in the Installation Manual which is included with the device.**

#### 11.1.2 People Counter ID ISC.ANT.GPC

This RF equipment is in compliance with the essential requirements and other relevant provisions of Directive 1999/5/EC dated March 99.



Equipment Classification according to ETSI EN 300 330 and ETSI EN 301 489: Class 2

**IDENTIFICATION**

**11.2 USA (FCC) and Canada (IC)**

11.2.1 Antenna ID ISC.ANT1710/690-Crystal Gate Excellence



<b>Product name:</b>	<b>ID ISC.ANT1710/690 Crystal Gate Excellence</b>
<b>Antenna name:</b>	<b>ID ISC.ANT1710/690 Type A Crystal Gate Excellence</b>
<b>Reader name:</b>	<b>ID ISC.LRM2500-BB</b>
<b>FCC ID:</b> <b>IC:</b>	<b>PJMLRM2500</b> <b>6633A-LRM2500</b>
<p><b>Notice for USA and Canada</b></p> 	<p>This device complies with Part 15 of the FCC Rules and with RSS-210 of Industry Canada.</p> <p>Operation is subject to the following two conditions.</p> <p>(1) this device may not cause harmful interference, and</p> <p>(2) this device must accept any interference received, including interference that may cause undesired operation.</p> <p>Unauthorized modifications may void the authority granted under Federal communications Commission Rules permitting the operation of this device.</p> <p>This equipment has been tested and found to comply with the limits for a Class A digital device, pursuant to Part 15 of the FCC Rules. These limits are designed to provide reasonable protection against harmful interference when the equipment is operated in a commercial environment. This equipment generates, uses, and can radiate radio frequency energy and, if not installed and used in accordance with the instruction manual, may cause harmful interference to radio communications. Operation of this equipment in a residential area is likely to cause harmful interference in which case the user will be required to correct the interference at his own expense.</p> <p>Le présent appareil est conforme aux CNR d'Industrie Canada applicables aux appareils radio exempts de licence. L'exploitation est autorisée aux deux conditions suivantes :</p> <p>(1) l'appareil ne doit pas produire de brouillage, et</p> <p>(2) l'utilisateur de l'appareil doit accepter tout brouillage radioélectrique subi, même si le brouillage est susceptible d'en compromettre le fonctionnement.</p>

Further information and technical data of the ID ISC.LRM2500-BB Reader built into the ID ISC.ANT1710/690-A Crystal Gate Excellence antenna can be found in the Installation Manual of the reader.

11.2.2 People Counter ID ISC.ANT.GPC

<b>FCC ID:</b> <b>IC:</b>	<b>UXS-IPS154US</b> <b>6633A-GPC</b>
<b>Notice for Canada</b>	<p>Operation is subject to the following two conditions:</p> <p>(1) this device may not cause interference, and (2) this device must accept any interference, including interference that may cause undesired operation of the device. Usually this is followed by the following RSS caution:</p> <p>Any changes or modifications not expressly approved by the party responsible for compliance could void the user's authority to operate this equipment.</p> <p>Le présent appareil est conforme aux CNR d'Industrie Canada applicables aux appareils radio exempts de licence. L'exploitation est autorisée aux deux conditions suivantes :</p> <p>(1) l'appareil ne doit pas produire de brouillage, et (2) l'utilisateur de l'appareil doit accepter tout brouillage radioélectrique subi, même si le brouillage est susceptible d'en compromettre le fonctionnement.</p>

### 11.3 USA and Canada (UL)

<p><b>UL</b> US <b>LISTED</b> Accessory I.T.E E304312</p> <p><b>FEIG</b> ELECTRONIC ID ISC.ANT1710/690-A Crystal Gate Excellence Input 24V  max. 1.5A This unit has to be supplied by a listed NEC Class 2/LPS Power Supply only. For use with connections to Listed ITE equipment and accessories only</p> <p>MAC: 00:1C:9B:04:39:30 Serial No.: 6890604</p> 	<p><b>UL</b> US <b>LISTED</b> Accessory I.T.E E304312</p> <p><b>FEIG</b> ELECTRONIC ID ISC.ANT1710/690-B Crystal Gate Excellence</p> <p>For use with connections to antenna ID ISC.ANT1710/690 Crystal Gate Excellence Type-A only.</p> <p>S.No.: 00000000</p> 
--	--

The following picture indicates the label position:



Fig. 32: Position of the label

**IDENTIFICATION**

**Annex**

**Annex A: Terminal Assignment "Terminal Board"**

Terminal	Acronym	Description
<b>X1 / LR</b>		<b>24V DC Reader</b>
X1 / Pin 1	24V	+24 V DC Reader
X1 / Pin 2	GND	GND Reader
<b>X2 / LR I/O</b>		<b>24V DC Input/Output , RS485</b>
X2 / Pin 1		RS485 A-
X2 / Pin 2		RS485 B+
X2 / Pin 3		GND
X2 / Pin 4		TRG Trigger People Counter
X2 / Pin 5		GND
X2 / Pin 6		Buzzer
X2 / Pin 7		Shield
<b>X3 / MUX</b>		<b>24V DC Multiplexer</b>
X3 / Pin 1	24V	+24 V DC Multiplexer
X3 / Pin 2	GND	GND Multiplexer
<b>X5 / GPC-in</b>		<b>Connection Cable to People Counter or LED</b>
X5 / Pin 1		+24V DC
X5 / Pin 2		GND People Counter or LED
X5 / Pin 3		RS485 A-
X5 / Pin 4		RS485B+
X5 / Pin 5		TRG Trigger People Counter
X5 / Pin 6		Shield
<b>X11</b>		<b>24V DC Power Supply</b>
X11 / Pin 1	24V	Power Supply +24 V DC
X11 / Pin 2	- / GND	Ground – Power Supply
<b>X13 / GPC-out</b>		<b>Connection Cable to next antenna</b>
X13 / Pin 1	24V	+24 V DC
X13 / Pin 2	GND	GND
X13 / Pin 3	TRG	TRG Trigger People Counter
X13 / Pin 4	A-	RS485 A-
X13 / Pin 5	B+	RS485 B+

Table 10: Pin-Configuration X1-X13 Terminal Board



**IDENTIFICATION**

**Annex B: Internal Wiring**

Terminal	Acronym	Description
<b>X1 / LR</b>		<b>24V DC Reader</b>
X1 / Pin 1		X13 +24 V DC Reader (red)
X1 / Pin 2	GND	X13 GND Reader (black)
<b>X2 / LR/I/O</b>		<b>24V DC Input/Output, RS485</b>
X2 / Pin 1		Reader LR2500 X3 Pin RS485 B+ (green)
X2 / Pin 2		Reader LR2500 X3 Pin RS485 A- (yellow)
X2 / Pin 3		Reader LR2500 X2 Pin IN2- (brown)
X2 / Pin 4		Reader LR2500 X2 Pin IN2+ (grey)
X2 / Pin 5		Reader LR2500 X3 Pin Out2-E (pink)
X2 / Pin 6		Reader LR2500 X2 Pin Out2-C (white)
X2 / Pin 7		Reader LR2500 X2 GND (black)
<b>X3 / MUX</b>		<b>24V DC Multiplexer</b>
X3 / Pin 1		X1 +24 V DC Multiplexer (red)
X3 / Pin 2	GND	X1 GND Multiplexer (black)
<b>X5 / GPC-in</b>		<b>Connection Cable to People Counter /LED</b>
X5 / Pin 1		GPC X1 Pin 1 +24 V DC GPC/LED (white)
X5 / Pin 2		GPC X1 Pin 2 GND GPC/LED (brown)
X5 / Pin 3		GPC X1 Pin 3 RS485-A (green)
X5 / Pin 4		GPC X1 Pin 4 RS485+B (yellow)
X5 / Pin 5		GPC X1 Pin 5 TRG Trigger People Counter (grey)
X5 / Pin 6		GPC X1 Pin 6 Shield

Table 11: Internal wiring