



Ingeniería Electrónica
SMART IDENT

COMPACT CARD DISPENSER

Specifications

User Manual

KHX-2200 Rev. C

Doc No	KHX-22XX SPECIFICATIONS	REV	PAGE	DATE
9100-0140		C	2 OF 22	2010. 02. 06

Compact Card Dispenser

WITH Capture Function integrated

Doc No	KHX-22XX SPECIFICATIONS	REV	PAGE	DATE
9100-0140		C	3 OF 22	2010. 02. 06

● **REVISION HISTORY**

CHECK	DATE	DESCRIPTION	REV.	PAGE
1	2009. 01. 19	First Edition	A	17
2	2010. 02. 06	TTL SPEC is added.	B	22

Doc No	KHX-22XX SPECIFICATIONS	REV	PAGE	DATE
9100-0140		C	4 OF 22	2010. 02. 06

C O N T E N T S

1. Overview
2. Features
3. System Block Diagram
4. Environmental Requirements
5. Specification
6. DC Power Connector
7. Interface
8. Technical Drawing
9. RS232C Interface
10. Card Status

Doc No	KHX-22XX SPECIFICATIONS	REV	PAGE	DATE
9100-0140		C	5 OF 22	2010. 02. 06

1. Overview

All the processes and operations of KHX-22XX are monitored by its intelligent Microprocessor, which makes itself self-recover function from faulty running.

KHX-22XX has a function to takes an Error card back to the bin. This function is called “Capture“.

There are 2 types of Interface for KHX-21XX Series, TTL Interface and RS-232C Interface, which can be integrated as User requires .

2. Features

2.1. Card thickness dispensable can be adjusted easily.

2.2. RS232C Interface

- A. Baud Rate: changeable (9,600 BPS ↔ 19,200BPS)
- B. Can change position of card (one way direction allowed)
- C. With self-diagnosis function.
- D. Easy to control

2.3. TTL Interface

2.4. KHX-22XX series are applied and integrated to following products and systems;

- Prepaid card vending machine
- ID card issuing machine
- Parking card vending machine
- Payphone card vending machine
- Automatic card issuing machine
- Ticketing vending machine
- And more

Doc No	KHX-22XX SPECIFICATIONS	REV	PAGE	DATE
9100-0140		C	6 OF 22	2010. 02. 06

2.5. Card Capture Function

- An error card is captured to bin.

2.6. Intelligent monitoring all the process cards empty and card low level warning

function with its own microprocessor

3. System Block Diagram

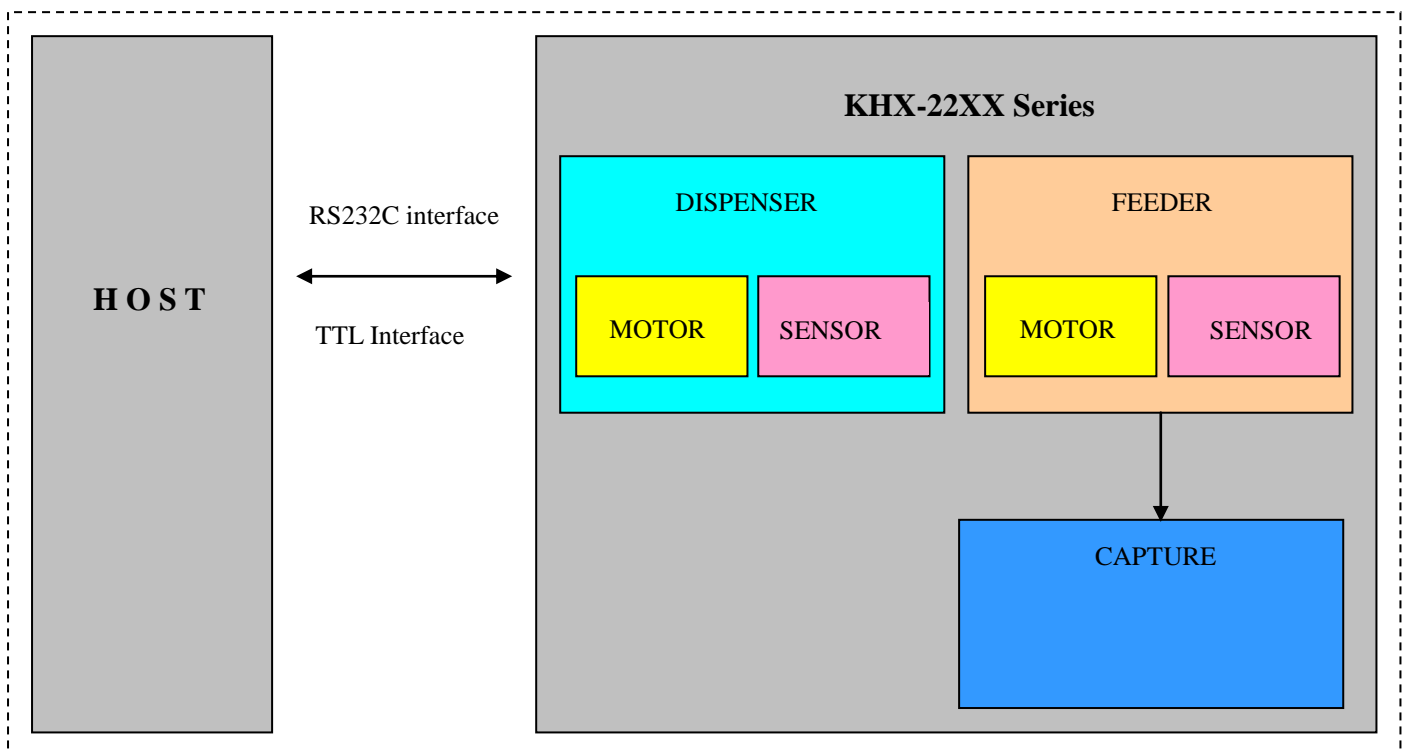

Doc No	KHX-22XX SPECIFICATIONS	REV	PAGE	DATE
9100-0140		C	7 OF 22	2010. 02. 06

5. Specifications.

5.1. Model.

MODEL	KHX-221X	KHX-222X	KHX-223X	KHX-224X
Dimensions (W x L x H) mm	Refer to Page 15			
Card Dispensing Time (Sec)	1.2	1.2	1.2	1.2
Max. Card Loading Capacity	100 PCS	200 PCS	300 PCS	500 PCS
	In case of 0.76 mm card			
Card Material	P.V.C			
Max. Card Width, Length	ISO 7810			
Max. Card Thickness	0.76~1.0 mm			
Environmental Requirements	<ol style="list-style-type: none"> Operating Temperature and Humidity: 0~40°C, 0~95% RH Conservation Temperature and Humidity: -20~70°C, 0~95% RH 			
Power Consumption	<ol style="list-style-type: none"> DC Motor Driver: Output Current 1.5A per channel. Input voltage: DC 24V Only (DC±5%, Min. 2.5A) Standby: 44 mA(+5%). 			

Doc No	KHX-22XX SPECIFICATIONS	REV	PAGE	DATE
9100-0140		C	8 OF 22	2010. 02. 06

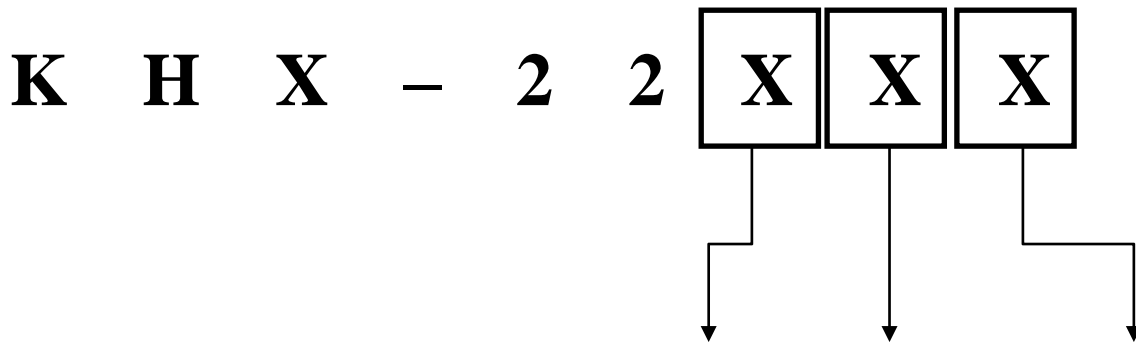

INTERFACE	FUNCTION	TYPE	CAPACITY	THICKNESS	OPTION
T: RS-232C L:TTL	2: Dispenser	2: Single Stacker & Card Capture Function	1: 100 PCS 2: 200 PCS 3: 300 PCS 4: 500 PCS	4: 0.76T 5: 0.84T 6: 1.00T	A: With Bezel B: Without Bezel C: With Bezel & DC Power Jack type (RS-232C ONLY) D: Without Bezel & DC Power Jack type (RS-232C ONLY)

Doc No	KHX-22XX SPECIFICATIONS	REV	PAGE	DATE
9100-0140		C	9 OF 22	2010. 02. 06

6. DC Power Connector(RS-232C ONLY)

6.1. Connector number: J6

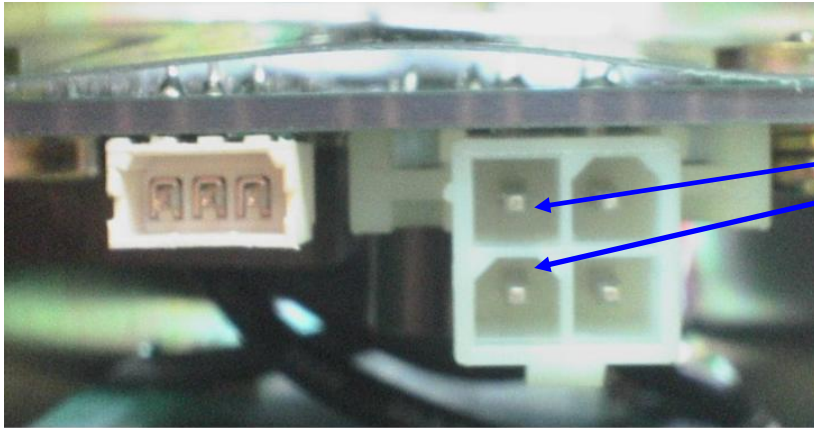

Pin 1. GND
Pin 3. +24V

Pin NO.	Signal Name	Direction
1	GND	Input
2	Not use	
3	+24V	
4	Not use	

6.2. Connector number: J7 (Option)

-DC Power Jack

Pin NO.	Signal Name	Direction
1	GND	Input
2	GND	
3	DC +24V	

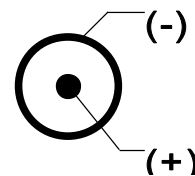

Doc No	KHX-22XX SPECIFICATIONS	REV	PAGE	DATE
9100-0140		C	10 OF 22	2010. 02. 06

7. Interface

7.1 RS232C type model

. Interface connector:

When use the KHX-2100's com-cable, connect to twist cable.

When use the user's com-cable, connect to as bellows table

. Connector number: J1

. Connector signal table

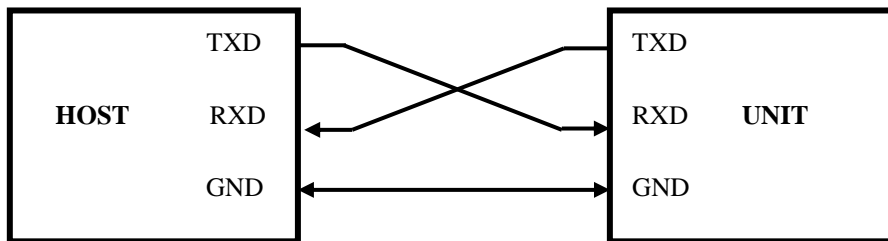

Pin No.	Index	KHX-21XX	HOST	Dsub-9	Remark
1	RXD	←		3	Receive
2	TXD	→		2	Transmit
3	GND	↔		5	S.G

. Communication Method

- Asynchronous, Half duplex.
- Baud Rate: 9600, 19200BPS (Default: 9600BPS)
- Data Length: 8Bits
- Parity: None
- Stop Bit: 1Bit

Doc No	KHX-22XX SPECIFICATIONS	REV	PAGE	DATE
9100-0140		C	11 OF 22	2010. 02. 06

7.2 TTL type model

Interface connector:

- Part number: HIF3F-20PA-2.54DS, Manufacture: HIROSE

Connector number: J1

Connector signal table

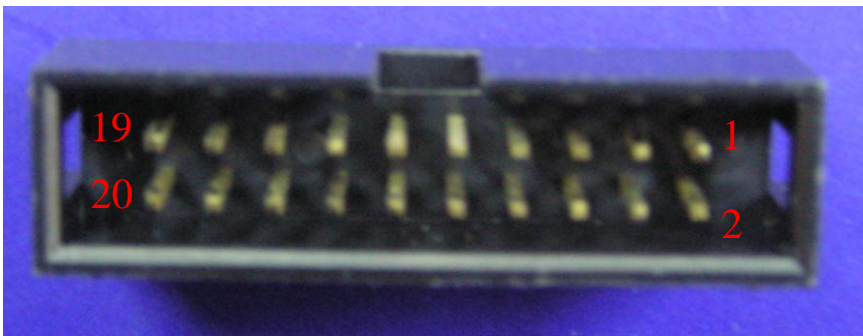

No.	Signal Name	Input /Output	Function	Configuration	Remark
1	VCC	Input			+24V
2	VCC	Input			+24V
3	D_MOT_ENA	Input			DISPENSER MOTOR
4	D_MOT_A	Input			
5	D_MOT_B	Input			
6	F_MOT_ENA	Input			FEEDING MOTOR
7	F_MOT_A	Input			
8	F_MOT_B	Input			
9	SENSOR_1	Output	Detected by sensor	Active High	FEED1 SENSOR
10	SENSOR_2	Output	Detected by sensor	Active High	FEED2 SENSOR
11	SENSOR_3	Output	Detected by sensor	Active High	FEED3 SENSOR
12	SENSOR_4	Output	Detected by sensor	Active High	EMPTY SENSOR
13	SENSOR_5	Output	Detected by sensor	Active Low	WARNING SENSOR
14	SENSOR_6	Output	Detected by sensor	Active High	BACK SENSOR
15	SENSOR_7	Output	Detected by sensor	Active High	FRONT SENSOR
16	-				
17	-				
18	-				
19	GND	Input			
20	-				

Doc No	KHX-22XX SPECIFICATIONS	REV	PAGE	DATE
9100-0140		C	12 OF 22	2010. 02. 06

* D.C Motor Control Table

INPUTS			FUNCTION
MOTOR_ENA	MOTOR_A	MOTOR_B	
H	L	H	Motor Regular Direction(LEFT)
H	H	L	Motor Reverse Direction(RIGHT)
H	MOTOR_A = MOTOR_B		Fast Motor Stop
L	X	X	Feed Running Motor Stop

H: HIGH

L: LOW

X: Don't Care

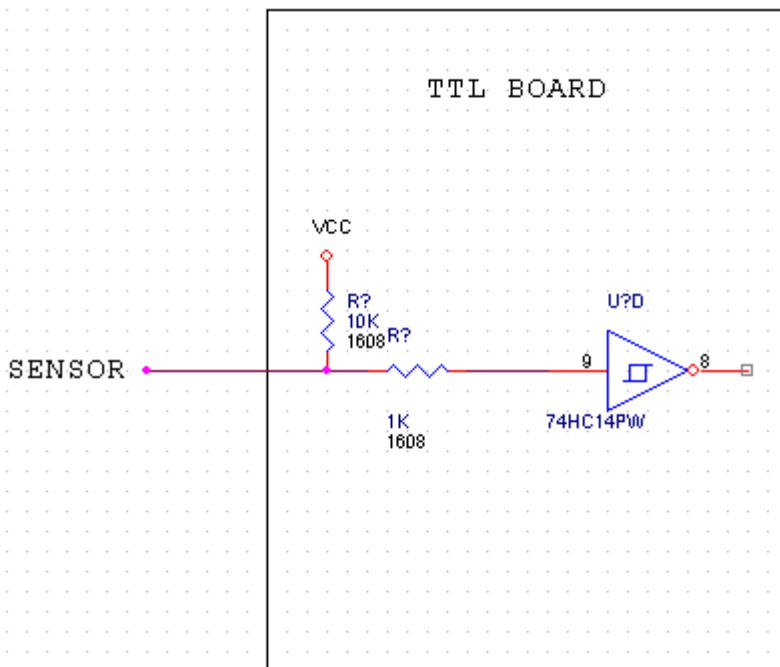

* Card detected signal (FEED1 SENSOR, FRONT SENSOR, EMPTY SENSOR, BACK SENSOR)



Doc No	KHX-22XX SPECIFICATIONS	REV	PAGE	DATE
9100-0140		C	13 OF 22	2010. 02. 06

* Card detected signal (WARNING SENSOR)

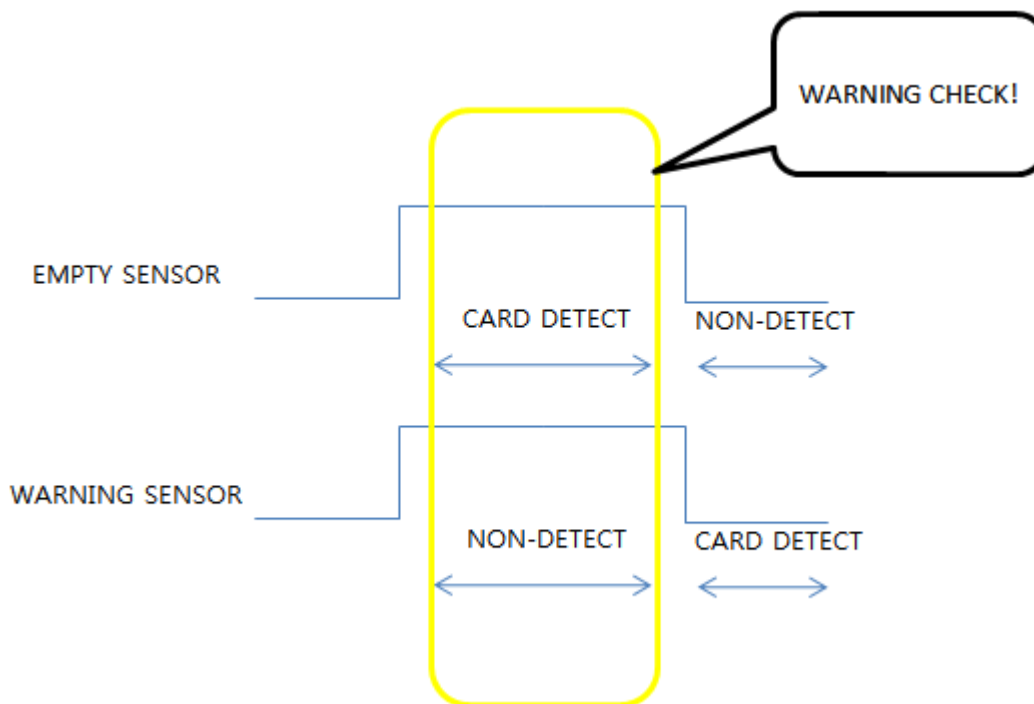

Doc No	KHX-22XX SPECIFICATIONS	REV	PAGE	DATE
9100-0140		C	14 OF 22	2010. 02. 06

★ MOTOR

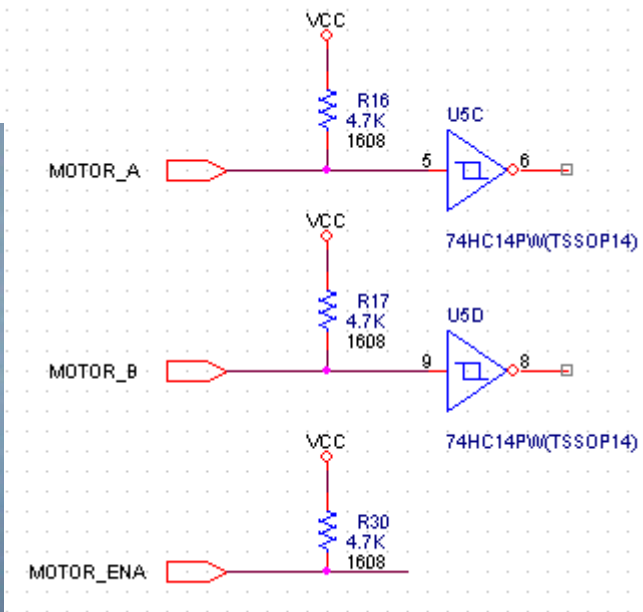

* Motor Regular Direction Signal(LEFT)

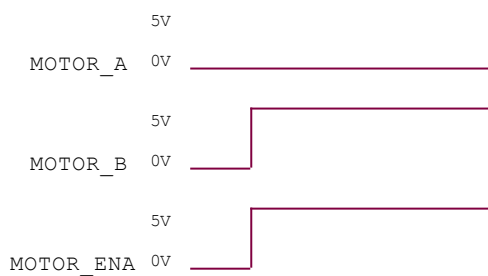

* Motor Reverse Direction Signal(RIGHT)

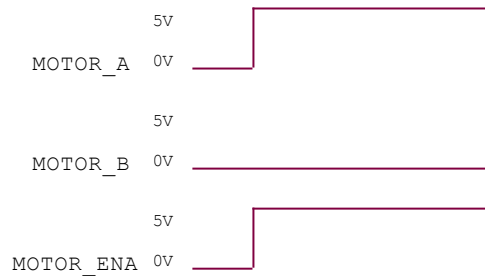

Doc No	KHX-22XX SPECIFICATIONS	REV	PAGE	DATE
9100-0140		C	15 OF 22	2010. 02. 06

* Fast Motor Stop Signal

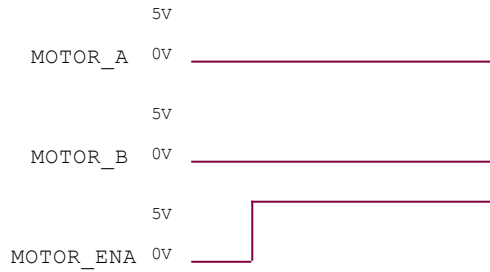

* Feed Running Motor Stop Signal

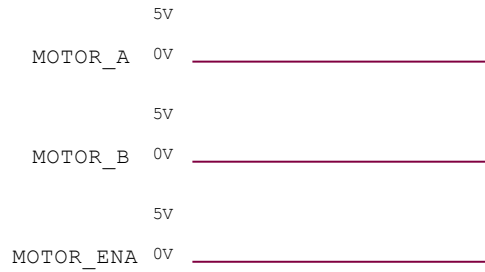

Doc No	KHX-22XX SPECIFICATIONS	REV	PAGE	DATE
9100-0140		C	16 OF 22	2010. 02. 06

***Timing Chart**

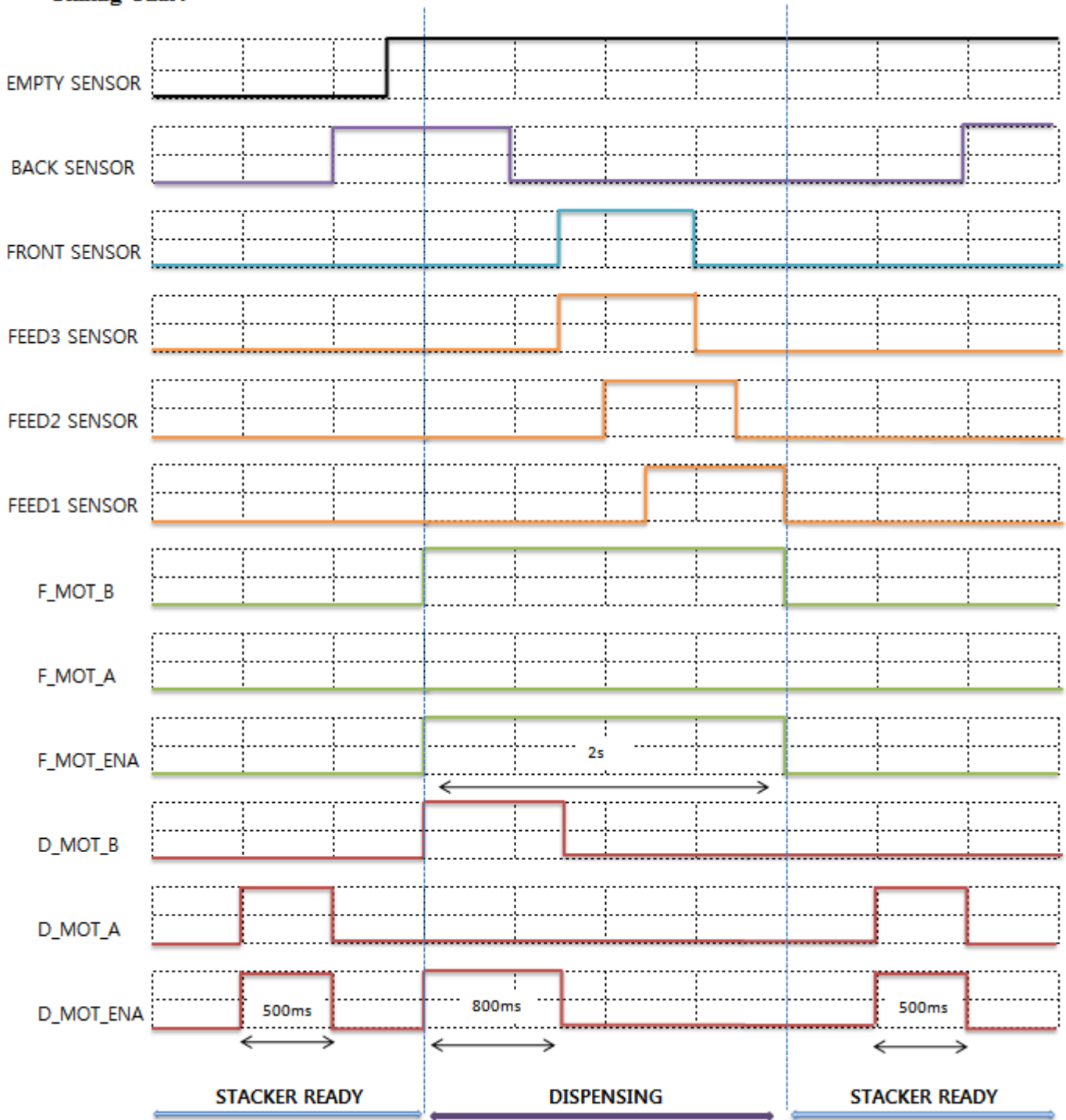

8. Technical Drawing

Doc No	KHX-22XX SPECIFICATIONS	REV	PAGE	DATE
9100-0140		C	17 OF 22	2010. 02. 06

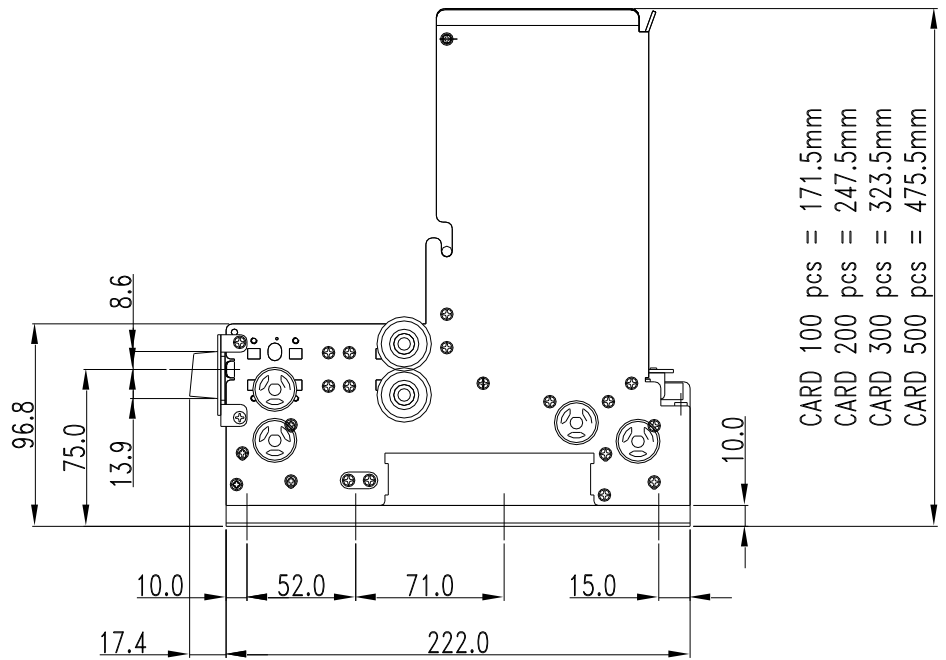
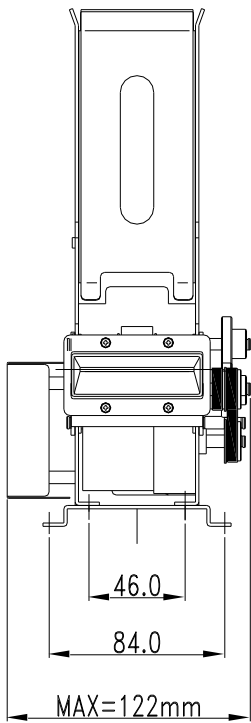
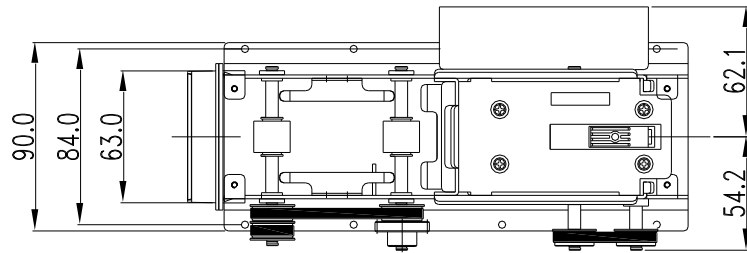

Doc No	KHX-22XX SPECIFICATIONS	REV	PAGE	DATE
9100-0140		C	18 OF 22	2010. 02. 06

<Sensor & Motor locations>

Connector No.	Remark
J3	Feed3 Sensor
J4	Feed2 Sensor
J5	Feed1 Sensor
J8	Empty Sensor
J13	Back Sensor
J14	Front Sensor
J9	Warning Sensor
J11	Feeder Motor
J12	Dispenser Motor

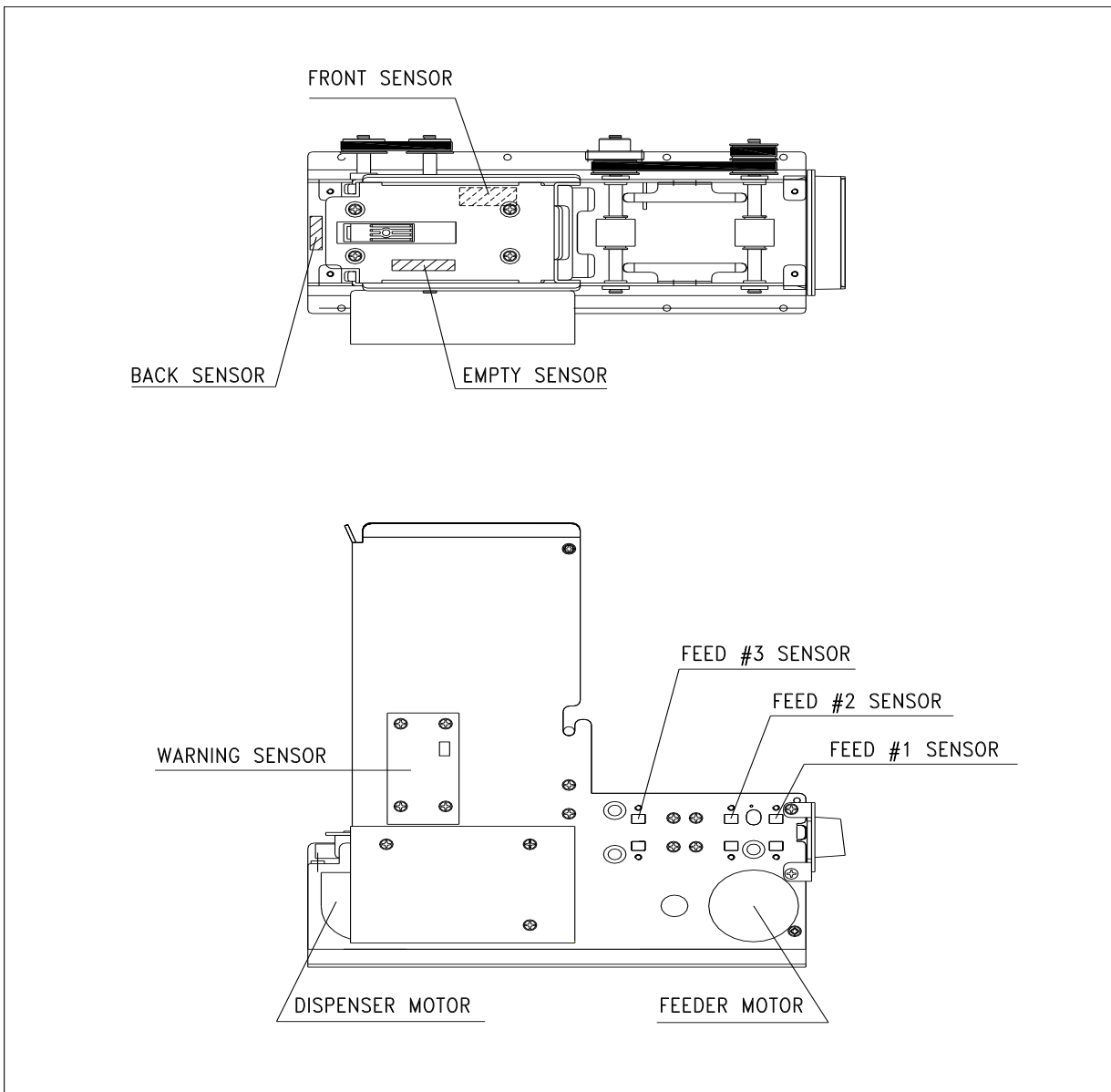

Doc No	KHX-22XX SPECIFICATIONS	REV	PAGE	DATE
9100-0140		C	19 OF 22	2010. 02. 06

9. RS232C Interface

9.1. Control Characters

Character	Hex Value	Description
STX	02	Start of Text Character
ETX	03	End of Text Character
EOT	04	End of Text Character
ENQ	05	Enquiry Character
ACK	06	Acknowledge Character
NAK	15	Negative Acknowledge Character
CAN	18	Cancel Character

9.2. Frame Format

Command structure

STX	Command	ETX	BCC
-----	---------	-----	-----

Response structure

STX	Status	Status	ETX	BCC
-----	--------	--------	-----	-----



$$BCC = STX \wedge (\text{Command and Status}) \wedge ETX$$

9.3. Communication Protocol Sequence

CASE 1)



CASE 2) Request Command (0x31)

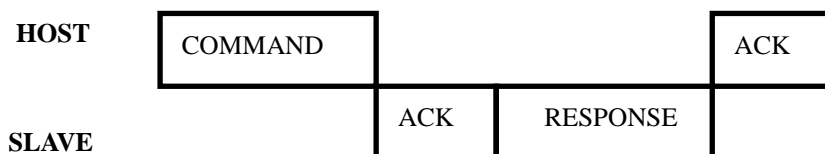

Doc No	KHX-22XX SPECIFICATIONS	REV	PAGE	DATE
9100-0140		C	20 OF 22	2010. 02. 06

CASE 2-1)

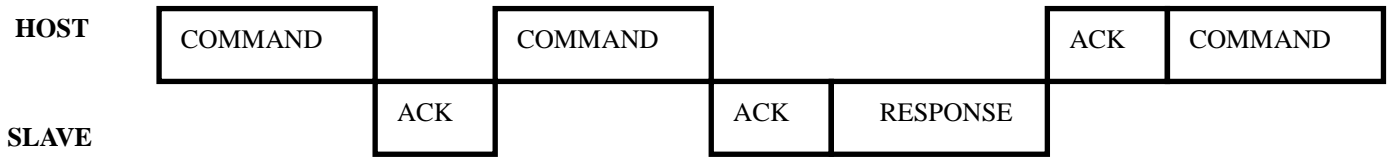

CASE 2-2)



CASE 2-3)

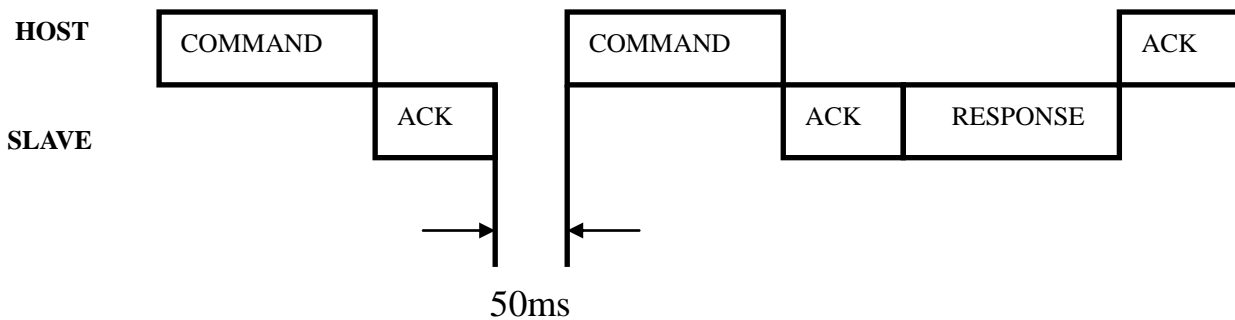

Cf.) To change Baud Rate, send command 50mS after receiving ACK.

Doc No	KHX-22XX SPECIFICATIONS	REV	PAGE	DATE
9100-0140		C	21 OF 22	2010. 02. 06

10.1. Command Sets List

Item	Command	Description	Note
Clear	0x30	Error Clear	
Request	0x31	Status Request	
Issue	0x40	Issue	
	0x41	Issue Feeder Standby	
Move	0x43	Feed In	
	0x44	Feed Out	
	0x45	Capture	
	0x46	Feed Stop	
	0x47	Feed Hold	
	0x48	Feeder Standby	
Baud Rate Set	0x60	Rom Version	
	0x50	9600 BPS Setting	Default
	0x51	19200 BPS Setting	

10.2. Command Details

10.2.1. Clear

: Clear Motor Jam bit of Status Request Command Response

※ Command Packet

STX	Command(0x30)	ETX	BCC
-----	---------------	-----	-----

10.2.2. Status Request

: Host's Request for status of dispenser

※ Command Packet

STX	Command(0x31)	ETX	BCC
-----	---------------	-----	-----

※ Response Packet

STX	Status 1	Status 2	ETX	BCC
-----	----------	----------	-----	-----

※ Status Data Format (Status 1) – cf.) Page 10

7	6	5	4	3	2	1	0
1	0	0	0	0	0	0	0

Data	Status 1	Remark
0x80	Good	Normal
0x81	Dispenser Jam	Dispenser Motor Jam
0x82	Feed Jam	Feed Motor Jam
0x84	Back Sensor Detection	Back Sensor Detection
0x88	Front Sensor Detection	Front Sensor Detection
0xc0	Busy	Ready

Doc No	KHX-22XX SPECIFICATIONS	REV	PAGE	DATE
9100-0140		C	22 OF 22	2010. 02. 06

※ Status Data Format (Status 2) – cf.) Page 10

7	6	5	4	3	2	1	0
1	0	0	0	0	0	0	0

Data	Status 2	Remark
0x80	Good	Normal
0x81	Card Empty	Dispenser Card Empty
0x82	Warning Sensor Detection.	Warning Sensor detect Card
0x84	Feed1 Sensor Detection	Feed Sensor detect Card
0x88	Feed2 Sensor Detection	
0x90	Feed3 Sensor Detection	

Stacker Status	Detail
'Stacker Good'	Good.
'Card Warning'	A few Card in the stacker
'Stacker Empty'	No cards in the stacker

-Warning Sensor Setting

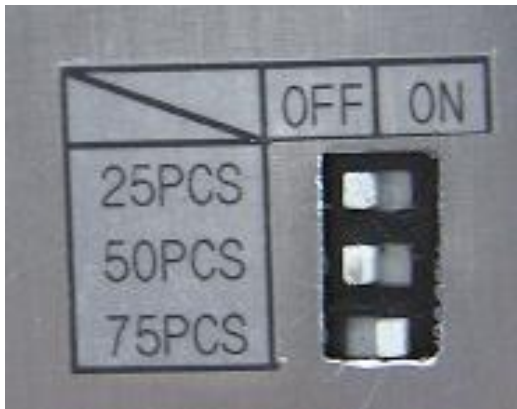

Set Value	25pcs	50pcs	75pcs
Set to 25pcs cards	ON	OFF	OFF
Set to 50pcs cards	OFF	ON	OFF
Set to 75pcs cards	OFF	OFF	ON

Doc No	KHX-22XX SPECIFICATIONS	REV	PAGE	DATE
9100-0140		C	23 OF 22	2010. 02. 06

10.2.3. Issue

: Dispense the card. And completely eject it from the feeder module.

While only feeder module sensors detect the card, if the unit receives “Feed Stop” command, the unit makes the card stop at once.

※ Command Packet

STX	Command(0x40)	ETX	BCC
-----	---------------	-----	-----

10.2.4. Issue Feeder Stand By

: Dispense the card and move it between Feed1 Sensor and Feed3 Sensor.

While only feeder module sensors detect the card, if the unit receives “Feed Stop” command, the unit makes the card stop at once.

※ Command Packet

STX	Command(0x41)	ETX	BCC
-----	---------------	-----	-----

10.2.5. Feeder Standby

: In the case that the card is present in the feeder module, move the card between Feed1 Sensor and Feed3 Sensor. And then if Sensor1 detect the card, move it between Feed1 Sensor and Feed3 Sensor.

While only feeder module sensors detect the card, if the unit receives “Feed Stop” command, the unit makes the card stop at once.

※ Command Packet

STX	Command(0x48)	ETX	BCC
-----	---------------	-----	-----

10.2.6. Feed In

: In the case that the card is present in the feeder module, move it to the stacker direction.

While only feeder module sensors detect the card, if the unit receives “Feed Stop” command, the unit makes the card stop at once.

※ Command Packet

STX	Command(0x43)	ETX	BCC
-----	---------------	-----	-----

10.2.7. Feed Out

: When the card is present in the feeder module, completely eject the card.

While only feeder module sensors detect the card, if the unit receives “Feed Stop” command, the unit makes the card stop at once.

※ Command Packet

STX	Command(0x44)	ETX	BCC
-----	---------------	-----	-----

Doc No	KHX-22XX SPECIFICATIONS	REV	PAGE	DATE
9100-0140		C	24 OF 22	2010. 02. 06

10.2.8. Capture

: When the card is present in the feeder module, capture the card.

If card is not present in the feeder module, spin the feeder motor in reverse direction during waiting time (1~5 seconds).

And then if Sensor1 detect the card in waiting time, capture it.

While only feeder module sensors detect the card, if the unit receives “Feed Stop” command, the unit makes the card stop at once.

※ Command Packet

STX	Command(0x45)	ETX	BCC
-----	---------------	-----	-----

★ **CAUTION: Capacity of the bin box are 15 PCS.**

10.2.9. Feed Stop

: This command stops the card when moving the card in the feeder module.

But that does not concern in the case that the card is not present in the feeder module.

※ Command Packet

STX	Command(0x46)	ETX	BCC
-----	---------------	-----	-----

10.2.10. Feed Hold

: Move the card to the outlet. And stop the card in Feed 1Sensor and Feed2 Sensor.

While only feeder module sensors detect the card, if the unit receives “Feed Stop” command, the unit makes the card stop at once.

※ Command Packet

STX	Command(0x47)	ETX	BCC
-----	---------------	-----	-----

10.2.11. Baud Rate Set

: Baud Rate Setting (After ACK receive, next Command should be transmitted after 50ms)
Case)

※ Command Packet (9600BPS)

STX	Command(0x50)	ETX	BCC
-----	---------------	-----	-----

10.2.12. Status of the card jam and the way to deal with the card jam

- Dispenser Jam

: Can't use all command except Status Request commands

(All jam is canceled and you can use these command, if Clear command is executed.)

- Feeder Jam

: Can't use all command except Status Request commands.

(All jam is canceled and you can use all command, if Clear command is executed)

- In the case that card is detected by Feed1 Sensor, Feed2 Sensor and Feed Sensor 3 at the same time.

: Can't use Issue, Issue Feeder Stand By commands.

But can use the feeder commands such as Capture, Feed In, Feed Out, Feed Hold, Feeder Standby.