



Ingeniería Electrónica
SMART IDENT

CARD COLLECTION MACHINE

Specifications

User Manual

CMT-1010 Rev. B

Doc No	CMT-101X SERIES SPECIFICATION	REV	PAGE	DATE
		B	3 OF 19	2006. 10. 31.

MODEL NAME INFORMATION

C M X - 1 0

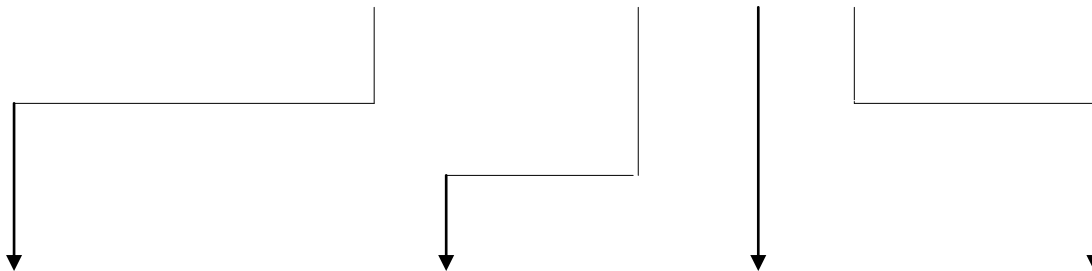

Interface	Function	TYPE	OPTION	CAPACITY
T: RS-232C L: TTL	COLLECTOR MODULE	0: SINGLE	0: STANDARD(Not Cartridge) 1: CARTRIDGE TYPE	1: 100 PCS 2: 200 PCS 3: 300 PCS 4: 500 PCS CARD STANDARD: 0.76T

Doc No	CMT-101X SERIES SPECIFICATION	REV	PAGE	DATE
		B	4 OF 19	2006. 10. 31.

C O N T E N T S

- 1. Overview**
- 2. Features**
- 3. System Block Diagram**
- 4. Specification**
- 5. Technical Drawing**
- 6. RS232C Interface**
- 7. TTL Interface**

Doc No	CMT-101X SERIES SPECIFICATION	REV	PAGE	DATE
		B	5 OF 19	2006. 10. 31.

1. OVERVIEW

There are 2 types of Interface for CMT-101X Series, TTL Interface and RS-232C Interface , which can be integrated as User requires .

2. Features

1. Card thickness dispensable can be adjusted easily .
Card thickness adjustable from 0.22mm up to 1.0mm
2. RS232C Interface
 - A. Baud Rate : changeable(9,600 BPS ↔ 19,200BPS)
 - B. Can change position of card (one way direction allowed)
 - C. With Self-diagnosis function
 - D. Easy to control
3. TTL Interface.
 - A. Can control Motor to change position of card (one way direction allowed)
 - B. Easy to control
4. FULL SENSOR is equipped to see card full status.

Doc No	CMT-101X SERIES SPECIFICATION	REV	PAGE	DATE
		B	6 OF 19	2006. 10. 31.

3. System Block Diagram

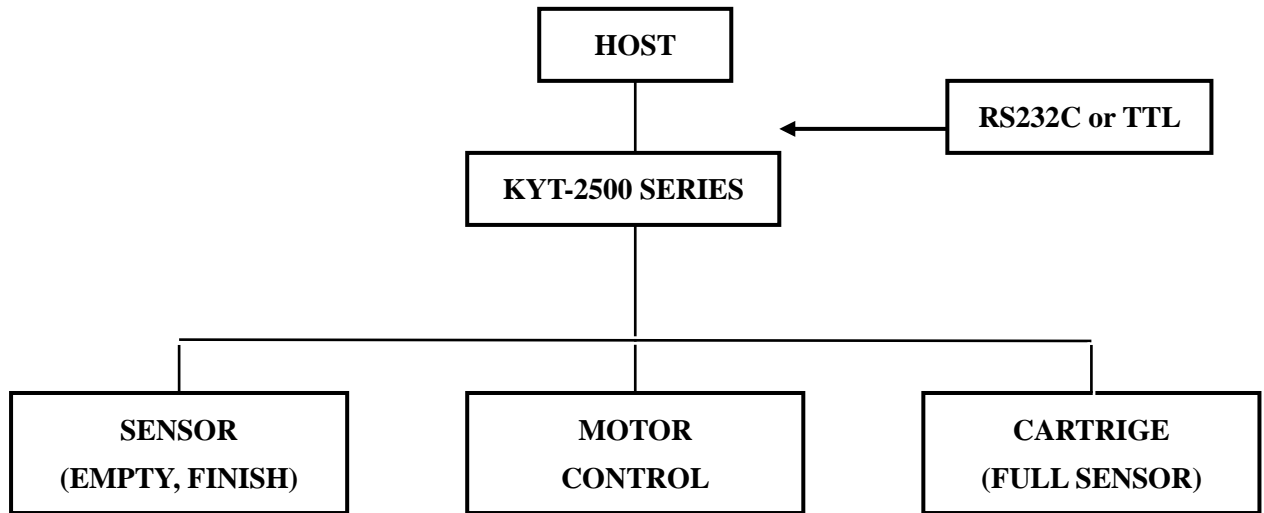

4. Specification

MODEL	CMT-1013	CML-1013	CMT-1014	CML-1014
Dimensions (W x L x H) mm				
Card Dispensing Time (Sec)	1.5	1.5	1.5	1.5
Max. Card Loading Capacity	(In case of 0.76 mm card) 300		(In case of 0.76 mm card) 500	
Total Weight (Kg)				
Card Material	P.V.C, A.B.S, P.E.T, etc.			
Max. Card Width, Max. Card Length	ISO 7810			
Max. Card Thickness	0.22 ~ 1.0 mm			
Supply Voltage & Current Consumption	Without Load : DC 24V(±5%) – 50 mA, With Load : DC 24V (±5%)– 1500 mA,			
Operating Humidity	0 % ~ 90 % RH			
Operating Temperature	-5° C ~ 70° C			

Doc No	CMT-101X SERIES SPECIFICATION	REV	PAGE	DATE
		B	7 OF 19	2006. 10. 31.

4.1 DC Power

- . Interface connector
 - Part Number : 5557-04A, Manufacture : MOLEX
- . Connector number : J6

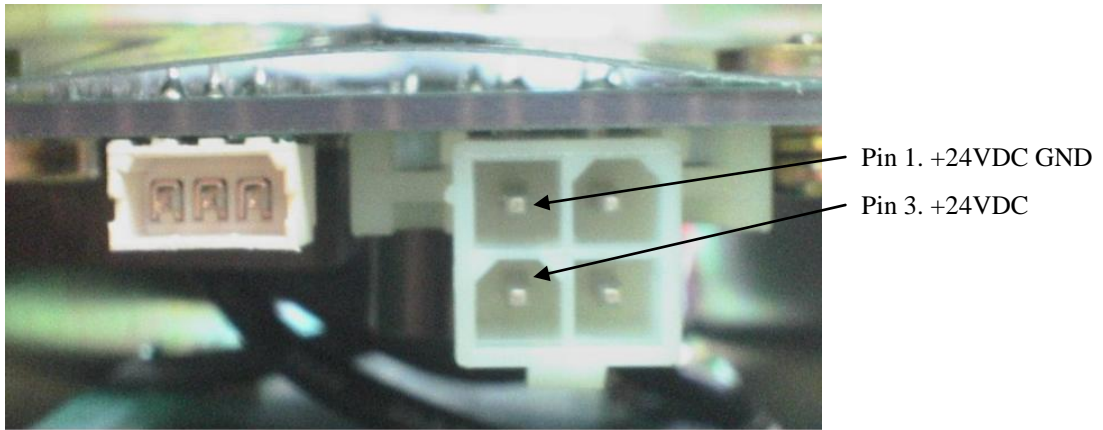

Pin NO	Signal Name	Cable color	Direction
1	GND	Black	Input
2	Not use		
3	+24VDC	Yellow	
4	Not use		

Doc No	CMT-101X SERIES SPECIFICATION	REV	PAGE	DATE
		B	8 OF 19	2006. 10. 31.

4.2 Interface

4.2.1 RS232C type model

. Interface connector :

Part number : 51004-0310, Manufacture : MOLEX

When use the CMT-101X's com-cable, connect to twist cable.

When use the user's com-cable, connect to as bellows table

. Connector number : J1

. Connector signal table

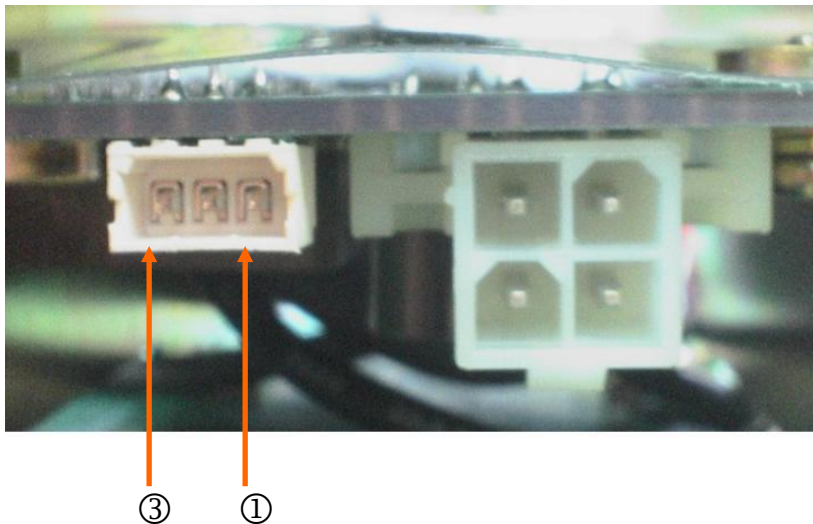

Pin No	Signal	CMT-101X-2500 HOST	Dsub-9	Remark
1	RXD	←	3	Receive data
2	TXD	→	2	Transmit data
3	GND	↔	5	Signal Ground

. Communication Method

- Asynchronous, Half duplex.
- Communication speed : 9600, 19200BPS (Default : 9600BPS)
- Data Length : 8Bits
- Parity : None
- Stop Bit : 1Bit

Doc No	CMT-101X SERIES SPECIFICATION	REV	PAGE	DATE
		B	9 OF 19	2006. 10. 31.

. Sensor definition

Connector No	NAME	Remark (As of CMT-101X)
J3	SEN1	Sensor #1
J4	SEN2	Optional
J5	SEN3	Sensor #2
J8	SEN4	Full sensor
J9	SEN5	Cartridge Contact

Doc No	CMT-101X SERIES SPECIFICATION	REV	PAGE	DATE
		B	10 OF 19	2006. 10. 31.

4.2.2 TTL type model

.Interface connector :

Part number : 51004-0710, Manufacture : MOLEX

. Connector number : J1-1

. Connector signal table

No	Signal Name	Input/Output	Function	Configuration
1	MOTOR_ENA	INPUT		
2	MOTOR_A	INPUT		
3	MOTOR_B	INPUT		
4	SENSOR #1	OUTPUT	Detected by sensor	Active High
5	SENSOR #2	OUTPUT	Detected by sensor	Active Low
6	GND(Common)	OUTPUT		
7	-	-	-	-
8	FULL SENSOR	OUTPUT	-	Active Low
9	CARTRIDGE CONTACT	OUTPUT		Active High
10	-	-	-	-

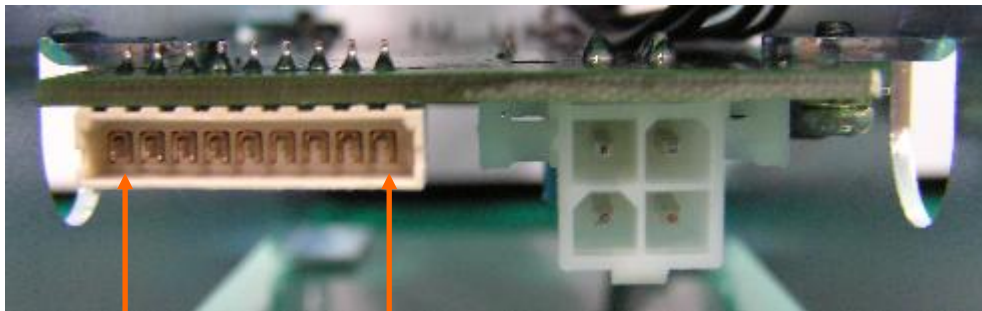

⑨

①

D.C Motor Control Table

INPUTS			FUNCTION
MOTOR_ENA	MOTOR_A	MOTOR_B	
H	L	H	Motor Regular Direction
H	H	L	Motor Reverse Direction
H	MOTOR_A = MOTOR_B		Fast Motor Stop
L	X	X	Feed Running Motor Stop

H : HIGH

L : LOW

X : Don't Care

Doc No	CMT-101X SERIES SPECIFICATION	REV	PAGE	DATE
		B	11 OF 19	2006. 10. 31.

5. Technical Drawing

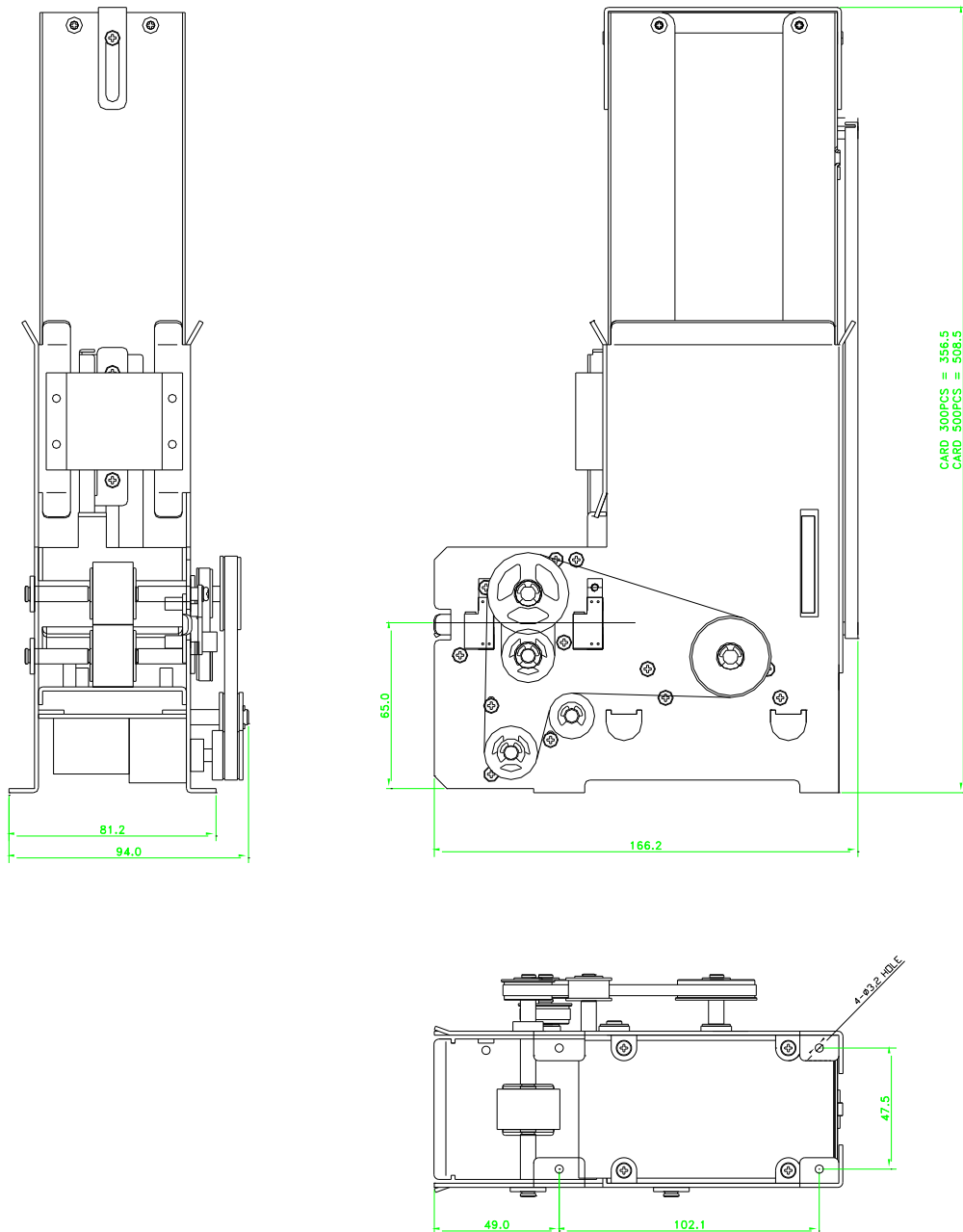

Doc No	CMT-101X SERIES SPECIFICATION	REV	PAGE	DATE
		B	12 OF 19	2006. 10. 31.

6. RS232C Interface

6.1. Control Characters

NANE	Hex Value	Description
STX	02	Start of Text
ETX	03	End of Text
EOT	04	End of Transmission
ENQ	05	Enquiry
ACK	06	Positive Acknowledge
NAK	15	Negative Acknowledge
CAN	18	Cancel

6.2. Frame Format

1. Command structure

STX	Command	ETX	BCC
-----	---------	-----	-----

2. Response structure

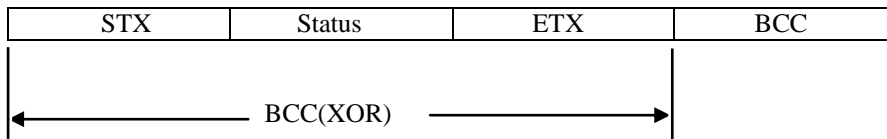

Doc No	CMT-101X SERIES SPECIFICATION	REV	PAGE	DATE
		B	13 OF 19	2006. 10. 31.

6.3. Communication Protocol Sequence

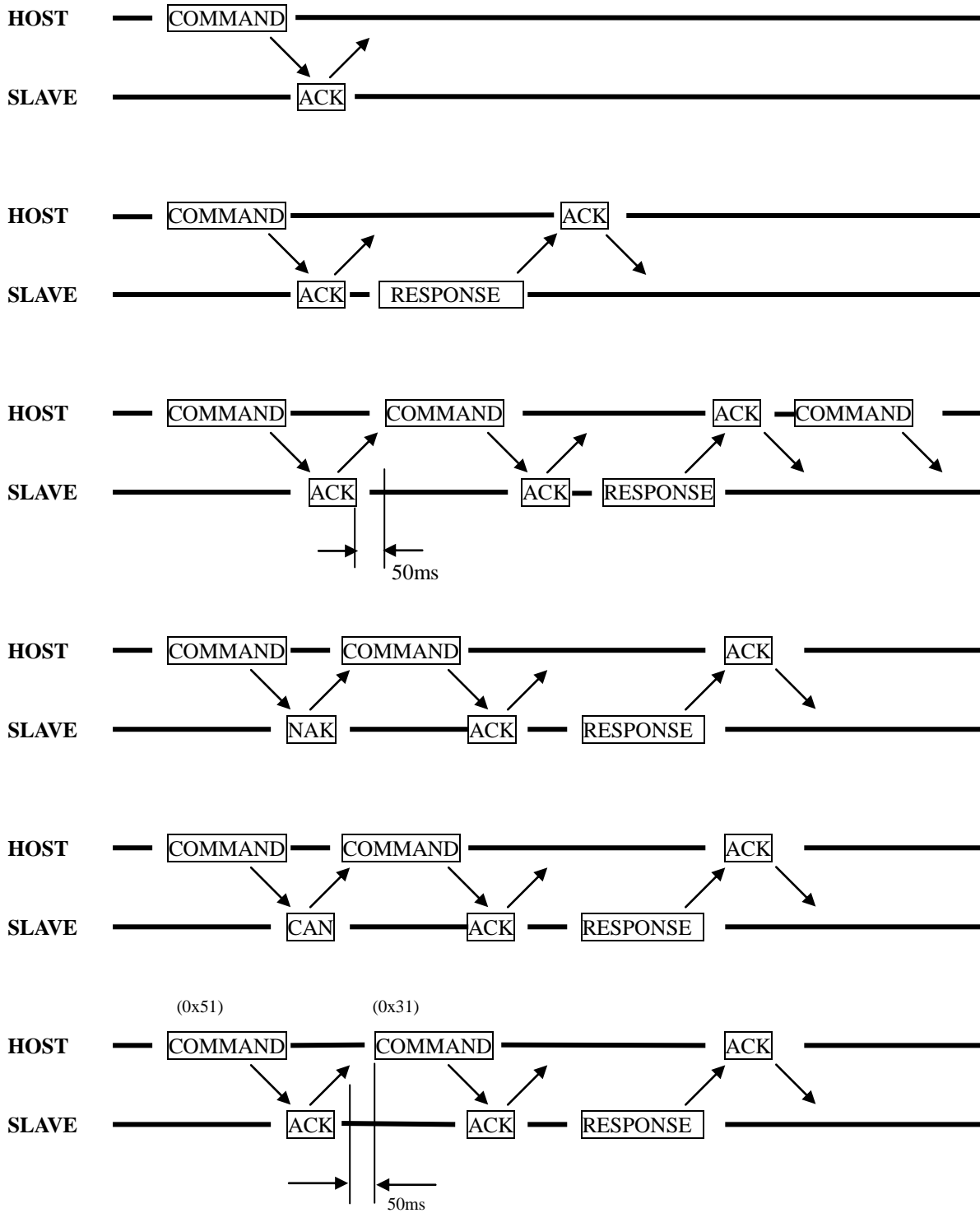

cf) To change Baud Rate , send command 50mS after receiving ACK .

Doc No	CMT-101X SERIES SPECIFICATION	REV	PAGE	DATE
		B	14 OF 19	2006. 10. 31.

6.4. Command Sets List

	Command	Description	Note
Clear	0x30	Error Clear	
Request	0x31	Status Request	
Card Collect	0x40	Card collect command	
Baud Rate Set	0x50	9600 BPS	
	0x51	19200 BPS	
Card Wait Time Set	0xF0	Non	
	0xF1	1 Sec	
	0xF2	2 Sec	
	0xF3	3 Sec	
	0xF4	4 Sec	
	0xF5	5 Sec	
	0xF6	6 Sec	
	0xF7	7 Sec	
	0xF8	8 Sec	
	0xF9	9 Sec	

Doc No	CMT-101X SERIES SPECIFICATION	REV	PAGE	DATE
		B	15 OF 19	2006. 10. 31.

6.5. Command Details

1. Clear

: Clear Motor Jam bit of Status Request Command Response

※ Command Packet

STX	Command(0x30)	ETX	BCC
-----	---------------	-----	-----

2. Status Request.

: Host's Request for status of dispenser

Command Packet

STX	Command(0x31)	ETX	BCC
-----	---------------	-----	-----

※ Response Packet

STX	Status	ETX	BCC
-----	--------	-----	-----

※ Status Data Format (1 byte) – Cf) Page 10

7	6	5	4	3	2	1	0
1	0	0	0	0	0	0	0

Data		
0x80	Good	Normal
0x81	Stacker Full Sensor	Stacker full status.
0x82	Sensor #1 Detection.	Front Sensor detect Card
0x84	Sensor#2 Detection.	Collector Sensor detect Card
0x90	Motor Jam.	Card Jam
0xA0	Cartridge Contact	Cartridge detect
0xc0	Collector Busy	Collector is running

3. Card Collect.

: Collect the cards on the stacker.

※ Command Packet

STX	Command(0x40)	ETX	BCC
-----	---------------	-----	-----

4. Baud Rate Set.

: Baud Rate Setting.(After ACK receive, next Command should be transmitted after 50ms)

4.1. 9600 BPS

※ Command Packet

STX	Command(0x50)	ETX	BCC
-----	---------------	-----	-----

Doc No	CMT-101X SERIES SPECIFICATION	REV	PAGE	DATE
		B	16 OF 19	2006. 10. 31.

4.2. 19200 BPS

× Command Packet

STX	Command(0x51)	ETX	BCC
-----	---------------	-----	-----

5. Card Wait Time Set.

: After Card Collect command transmit, set waiting time until SENSOR#1, SENSOR#2 detecting.

× Command Packet

STX	Command	ETX	BCC
-----	---------	-----	-----

Command List (cf. Page 14)

Doc No	CMT-101X SERIES SPECIFICATION	REV	PAGE	DATE
		B	17 OF 19	2006. 10. 31.

7. TTL Interface

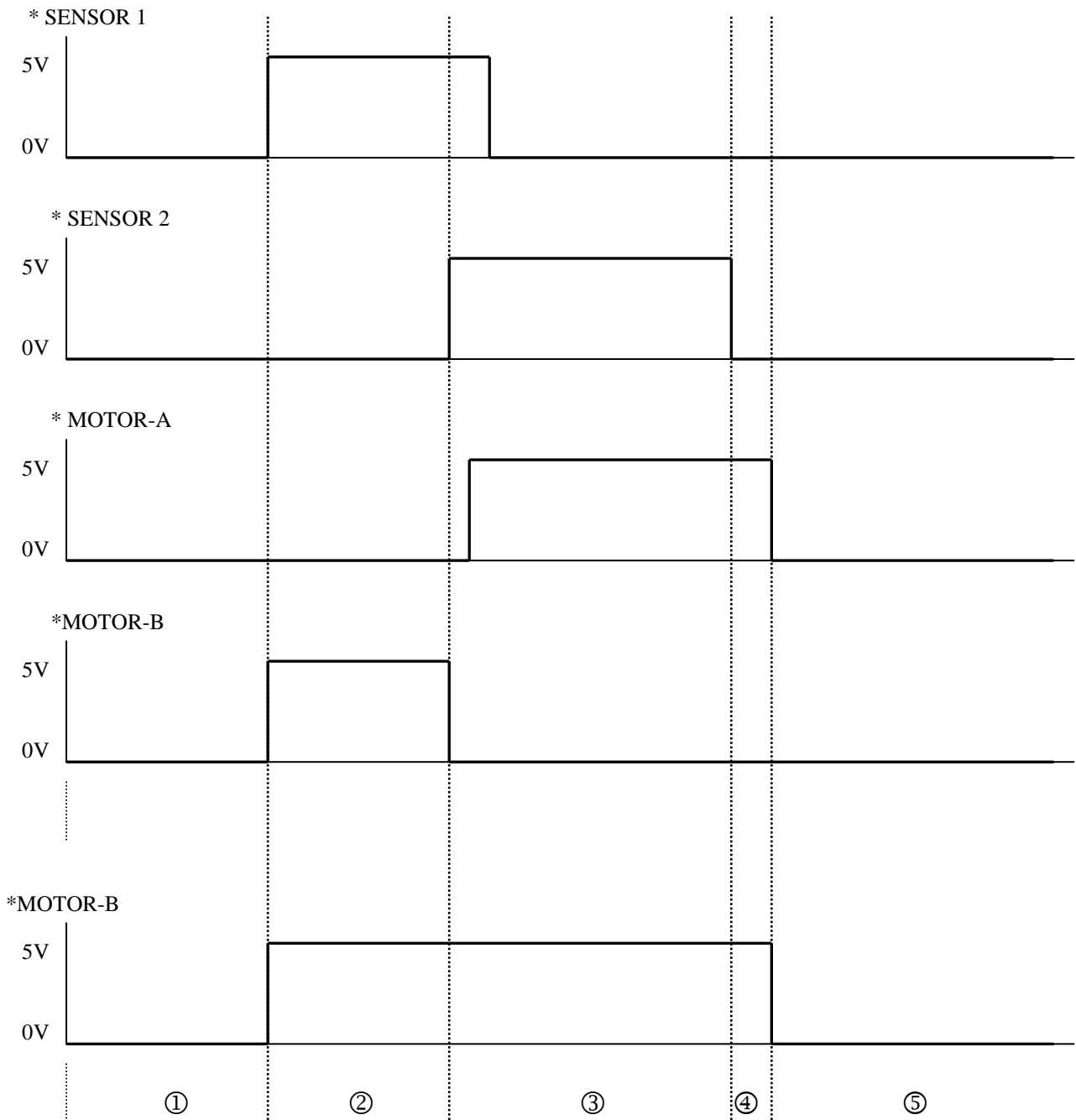

① : Dispenser Stand-by status.

② : Detect the SENSOR 1, and then Motor Run

③ : After Max 150mSec from detecting the SENSOR 2, run Motor to reverse direction

Doc No	CMT-101X SERIES SPECIFICATION	REV	PAGE	DATE
		B	18 OF 19	2006. 10. 31.

④ : After card moved out of SENSOR 2, Motor run for Min300ms.

⑤ : Stand-by status after 1 card collection.

Example 1) RS232 Control Example

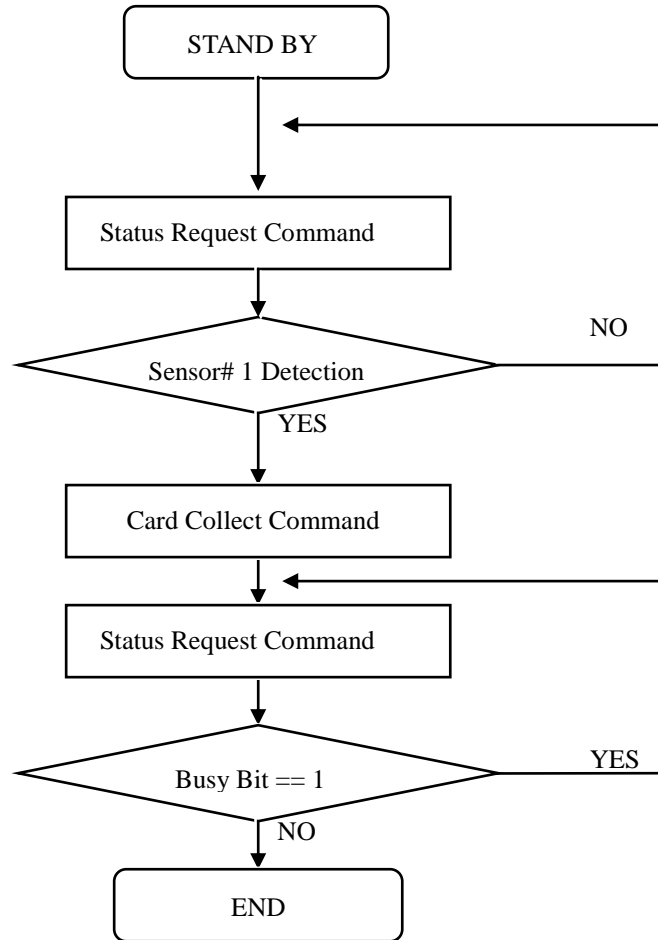

Doc No	CMT-101X SERIES SPECIFICATION	REV	PAGE	DATE
		B	19 OF 19	2006. 10. 31.

Example 2) TTL Control Example

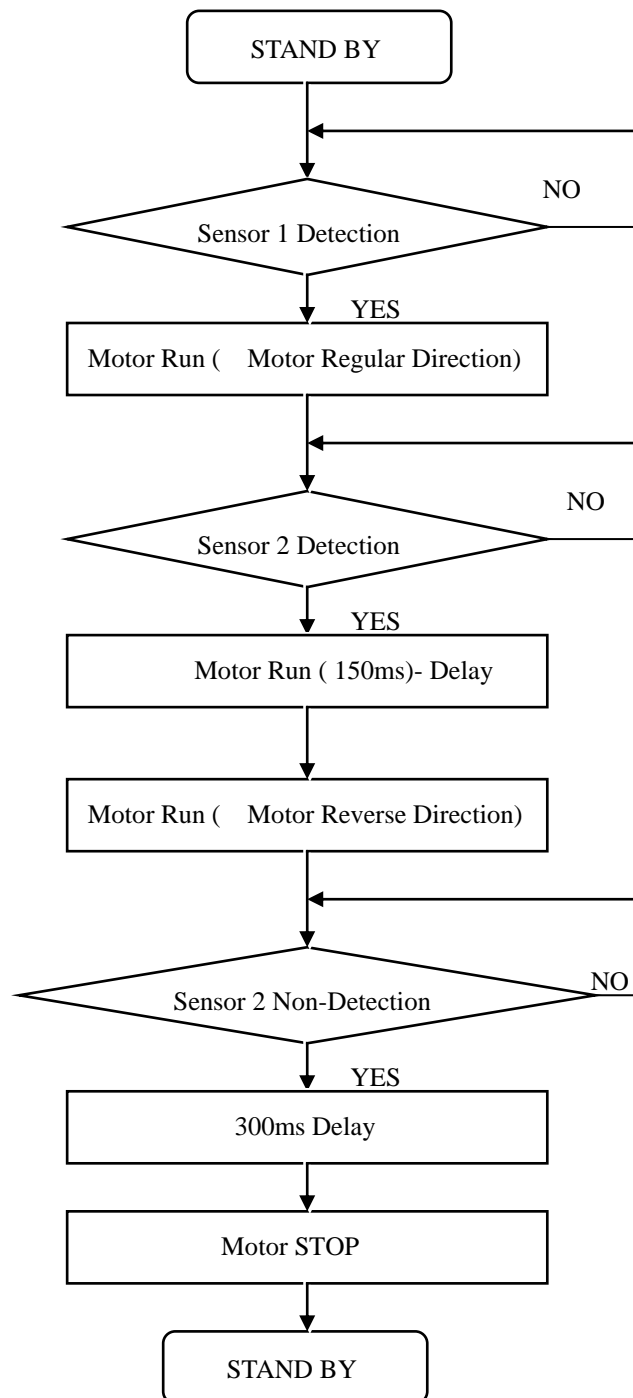

Doc No	CMT-101X SERIES SPECIFICATION	REV	PAGE	DATE
		B	20 OF 19	2006. 10. 31.

* SENSOR NAME.

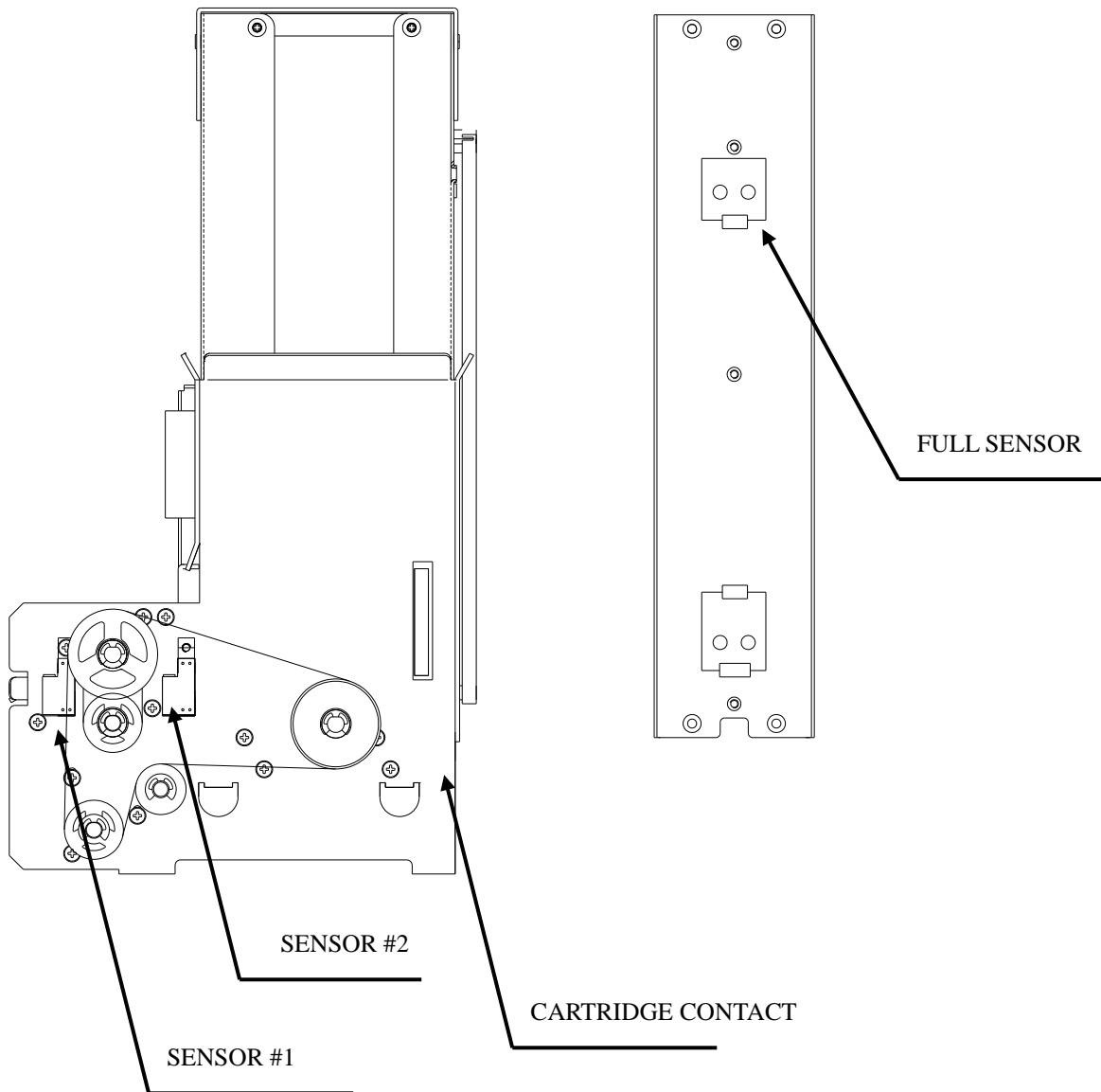

Doc No	CMT-101X SERIES SPECIFICATION	REV	PAGE	DATE
			B	21 OF 19