



Ingeniería Electrónica
SMART IDENT

KYX-1000
FEEDING MACHINE
Specifications

User Manual

KYX1000.UM.K.EN.doc

Doc No	KYX-1000 SPECIFICATION	REV	PAGE	DATE
		K	2 OF 24	2013. 07. 26.

REVISION HISTORY

CHECK	DATE	DESCRIPTION	REV	PAGE
1	2003.01		A	7
2	2004.10	BEZEL => SHORT BEZEL	B	
3	2005.12.1	Only DC 24V	C	8
4	2006.06.09	KYX1000 Model Change	D	16
5	2006.11.02	Modified the model name information in the SPEC	E	17
6	2006.12.04	SENSOR2 and SENSOR3 change	F	17
7	2007.07.03	0x4B, 0x44 command are added	G	17
8	2010.11.03	Technical drawing change	H	18
9	2011.05	Shutter function is added	I	18
10	2012.02	KYX-xxx2 option is added.	J	22
11	2013.07.26	Modified the model name	K	23

Doc No	KYX-1000 SPECIFICATION	REV	PAGE	DATE
			K	3 OF 24

C O N T E N T S

- 1. Overview**
- 2. Features**
- 3. System Block Diagram**
- 4. Specification**
- 5. Technical Drawing**

Doc No	KYX-1000 SPECIFICATION	REV	PAGE	DATE
		K	4 OF 24	2013. 07. 26.

MODEL NAME INFORMATION

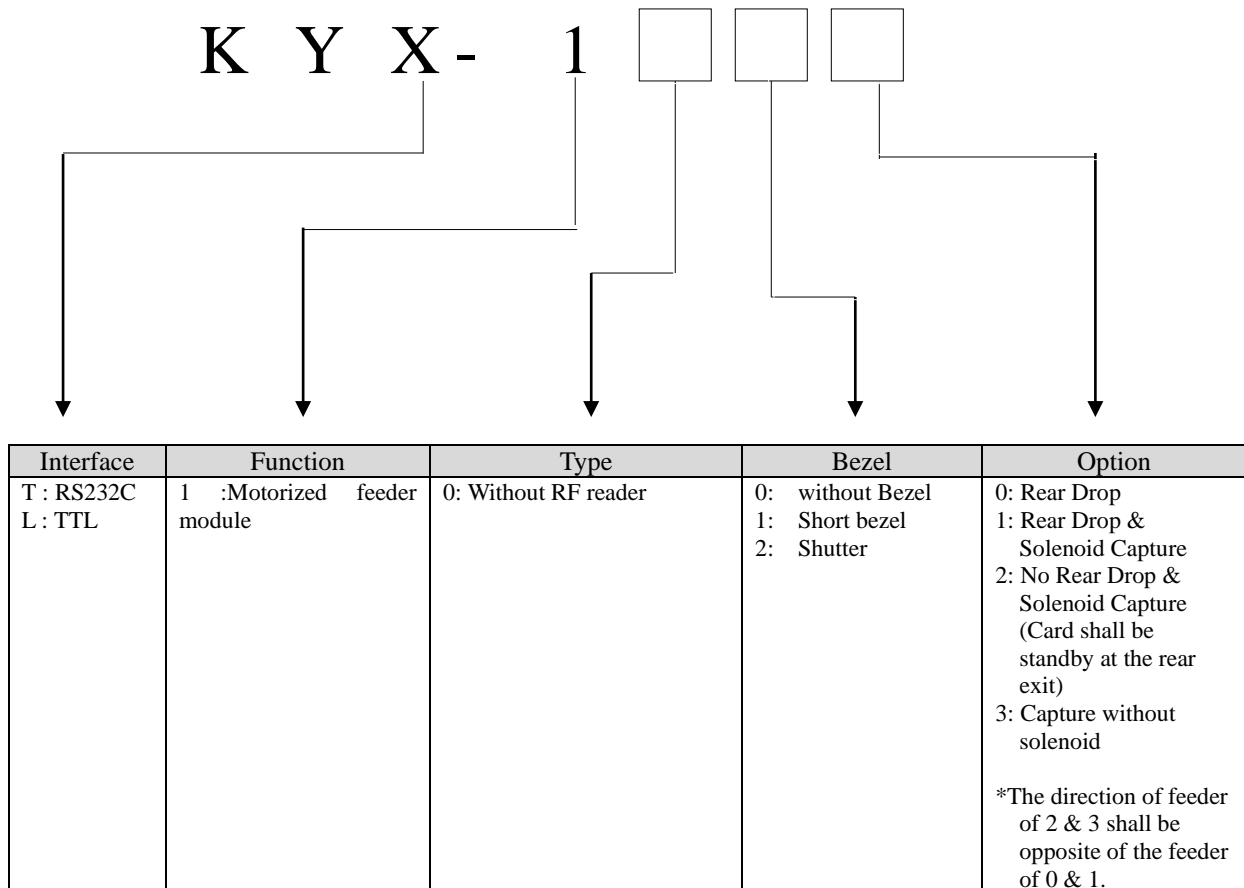

Doc No	KYX-1000 SPECIFICATION	REV	PAGE	DATE
		K	5 OF 24	2013. 07. 26.

1. OVERVIEW

There are 2 types of Interface for KYX-10XX Series, TTL Interface and RS-232C Interface, which can be integrated as User requires .

2. Features

1. RS232C Interface
 - A. Baud Rate : changeable(9,600 BPS ↔ 19,200BPS)
 - B. Easy to control
- 2.. TTL Interface
 - A. Can control Motor to change position of card.
 - B. Easy to control

3. System Block Diagram

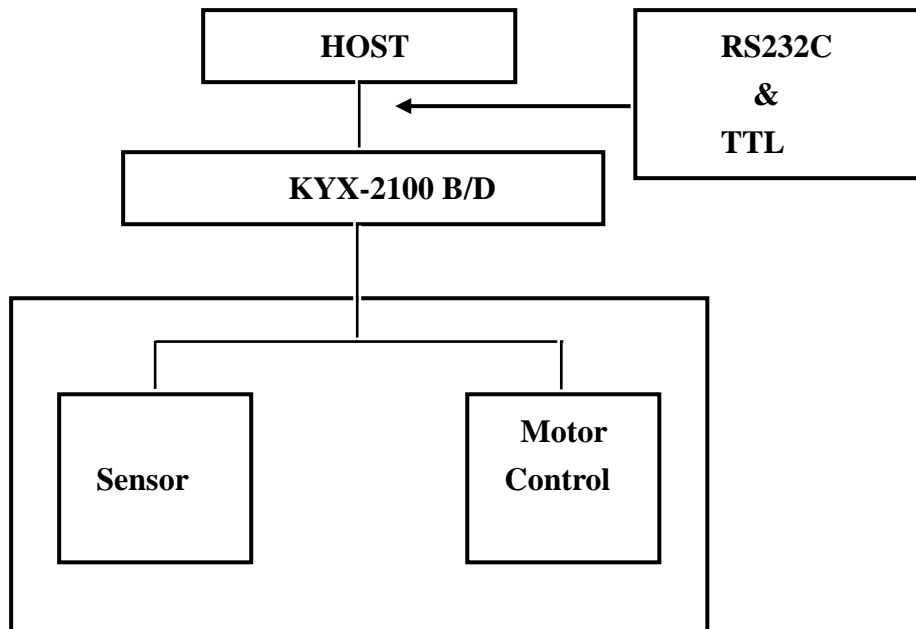

Doc No	KYX-1000 SPECIFICATION	REV	PAGE	DATE
		K	6 OF 24	2013. 07. 26.

4. Specification

4.1. DC Power Connector

. Interface connector

- Part Number : 5557-04A, Manufacture : MOLEX

. Connector number : J6

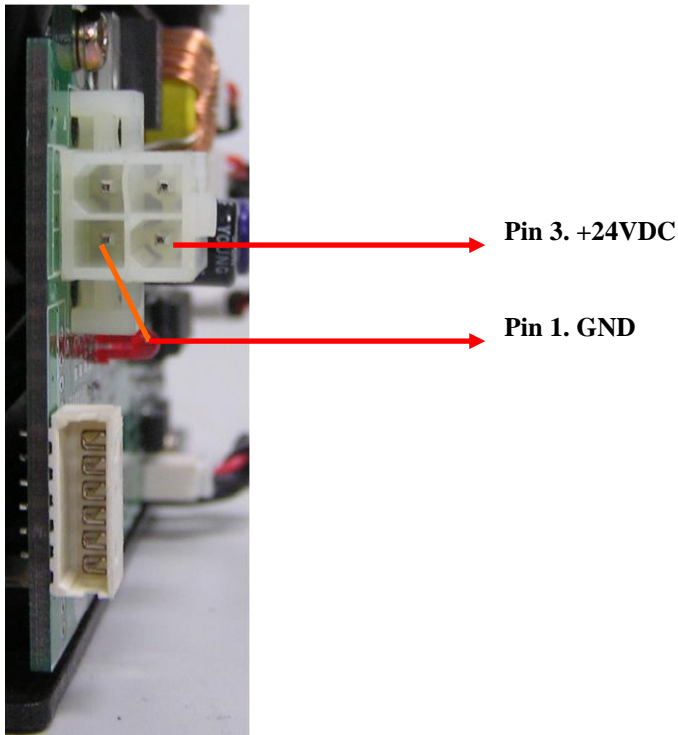

Pin NO	Signal Name	Cable color	Direction
1	GND	Black	Input
2	Not use		
3	+24VDC	Yellow	
4	Not use		

. Supply Voltage & Current Consumption

With Load : DC 24V ($\pm 5\%$)– 1500mA

Doc No	KYX-1000 SPECIFICATION	REV	PAGE	DATE
		K	7 OF 24	2013. 07. 26.

4.2 Interface

4.2.1 RS232C type model

. Interface connector :

Part number : 51004-0310, Manufacture : MOLEX

When use the KYT-10XX's com-cable, connect to twist cable.

When use the user's com-cable, connect to as bellows table

. Connector number : J1

. Connector signal table

Pin No	Signal	KYT-10XX	HOST	Dsub-9	Remark
1	RXD	←		3	Receive data
2	TXD	→		2	Transmit data
3	GND	↔		5	Signal Ground

. Communication Method

- Asynchronous, Half duplex.
- Communication speed : 9600, 19200BPS (Default : 9600BPS)
- Data Length : 8Bits
- Parity : None
- Stop Bit : 1Bit

Doc No	KYX-1000 SPECIFICATION	REV	PAGE	DATE
		K	8 OF 24	2013. 07. 26.

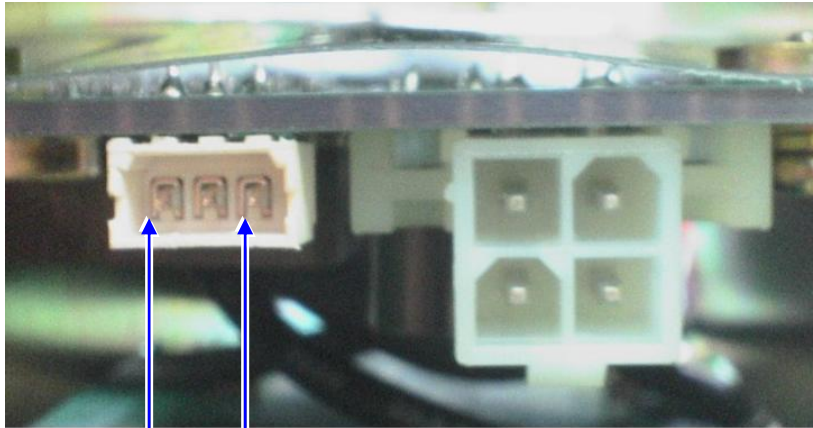

③ ①

4.2.2. Pin Definition Table (TTL Interface model)

- . Part Number : 53015-0710(MOLEX), Connector number : J7
- . Connect Pin Table (PCB side)

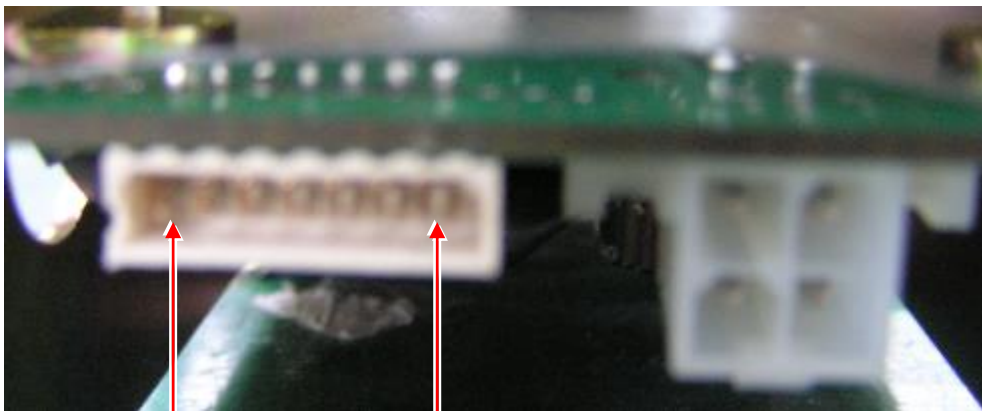

⑦ ①

* TTL Signal(MODEL – KYL10X0)

NO	FUNCTION	DIRECTION	ACTIVE	REMARK
1	MOTOR_ENA	Input	High	
2	MOTOR_A	Input		
3	MOTOR_B	Input		
4	SENSOR #1	Output	High	
5	SENSOR #3	Output	High	
6	Common GND	Input		
7	SENSOR #2	Output	High	

Doc No	KYX-1000 SPECIFICATION	REV	PAGE	DATE
		K	9 OF 24	2013. 07. 26.

*** TTL Signal(MODEL – KYL10X1)**

NO	FUNCTION	DIRECTION	ACTIVE	REMARK
1	MOTOR_ENA	Input	High	
2	MOTOR_A	Input		
3	MOTOR_B	Input		
4	SENSOR #1	Output	High	
5	SENSOR #3	Output	High	
6	Common GND	Input		
7	SENSOR #2	Output	High	
8	RFU	-	-	
9	RFU	-	-	
10	SOL_A	Output	Low	

.D.C Motor Control Table

INPUTS			FUNCTION	REMARK
MOTOR_ENA	MOTOR_A	MOTOR_B		
H	L	High	Motor Regular Direction	Ref)“7. TTL Interface”
H	H	Low	Motor Reverse Direction	
H	MOTOR_A = MOTOR_B		Fast Motor Stop	
L	X	X	Feed Running Motor Stop	

H : HIGH

L : LOW

C : Don't Care

Doc No	KYX-1000 SPECIFICATION	REV	PAGE	DATE
		K	10 OF 24	2013. 07. 26.

< CARD MOVE >

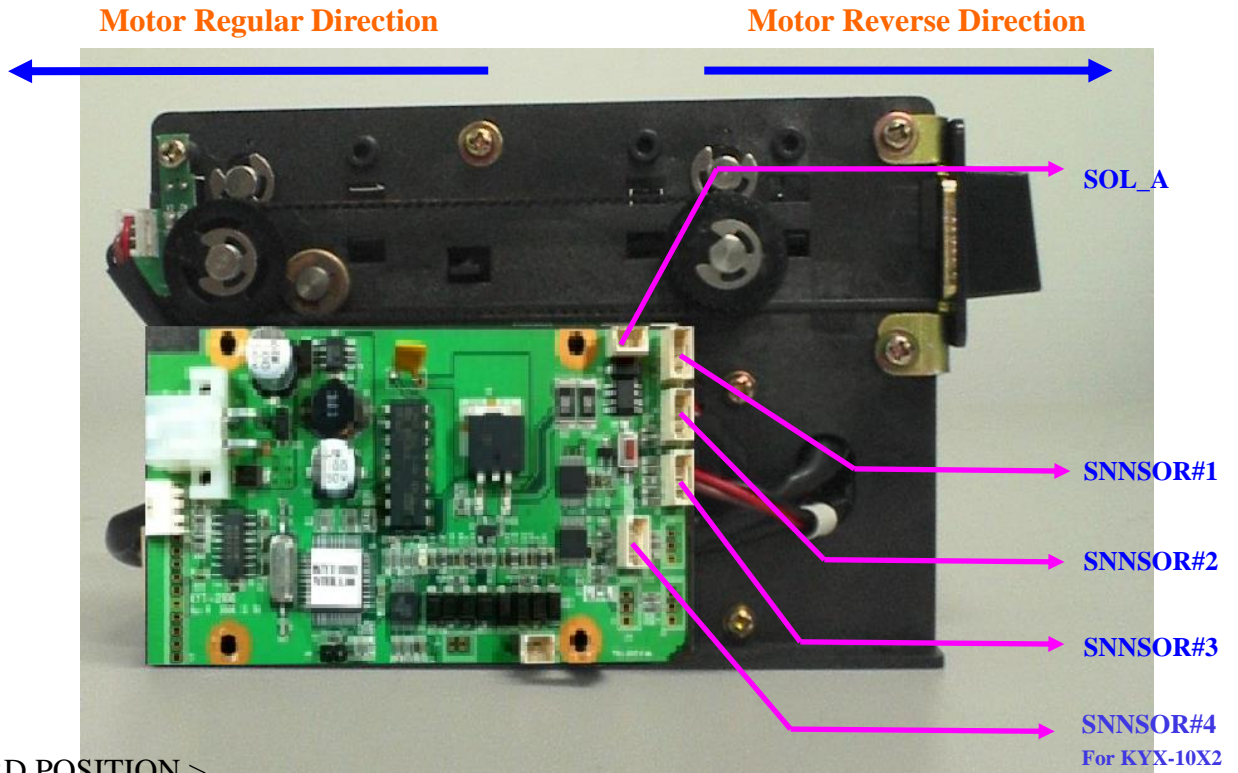

< CARD POSITION >

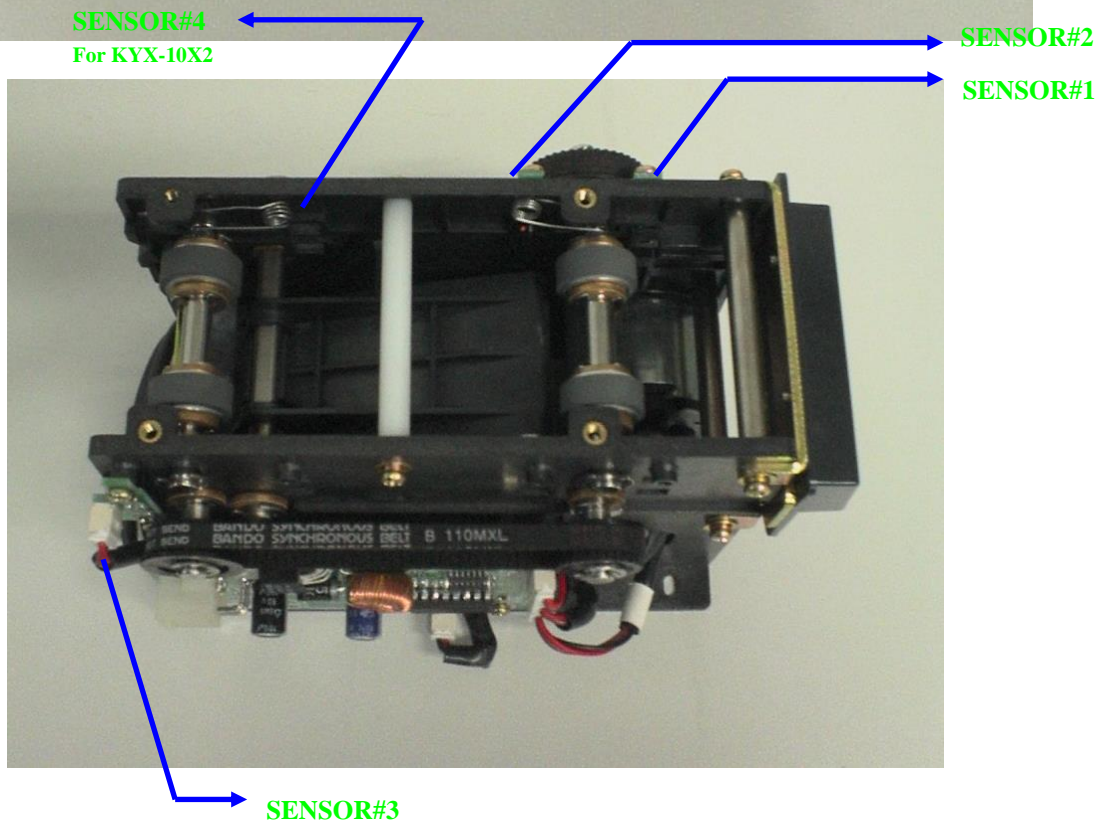

Doc No	KYX-1000 SPECIFICATION	REV	PAGE	DATE
		K	11 OF 24	2013. 07. 26.

MODEL – KYX-1000

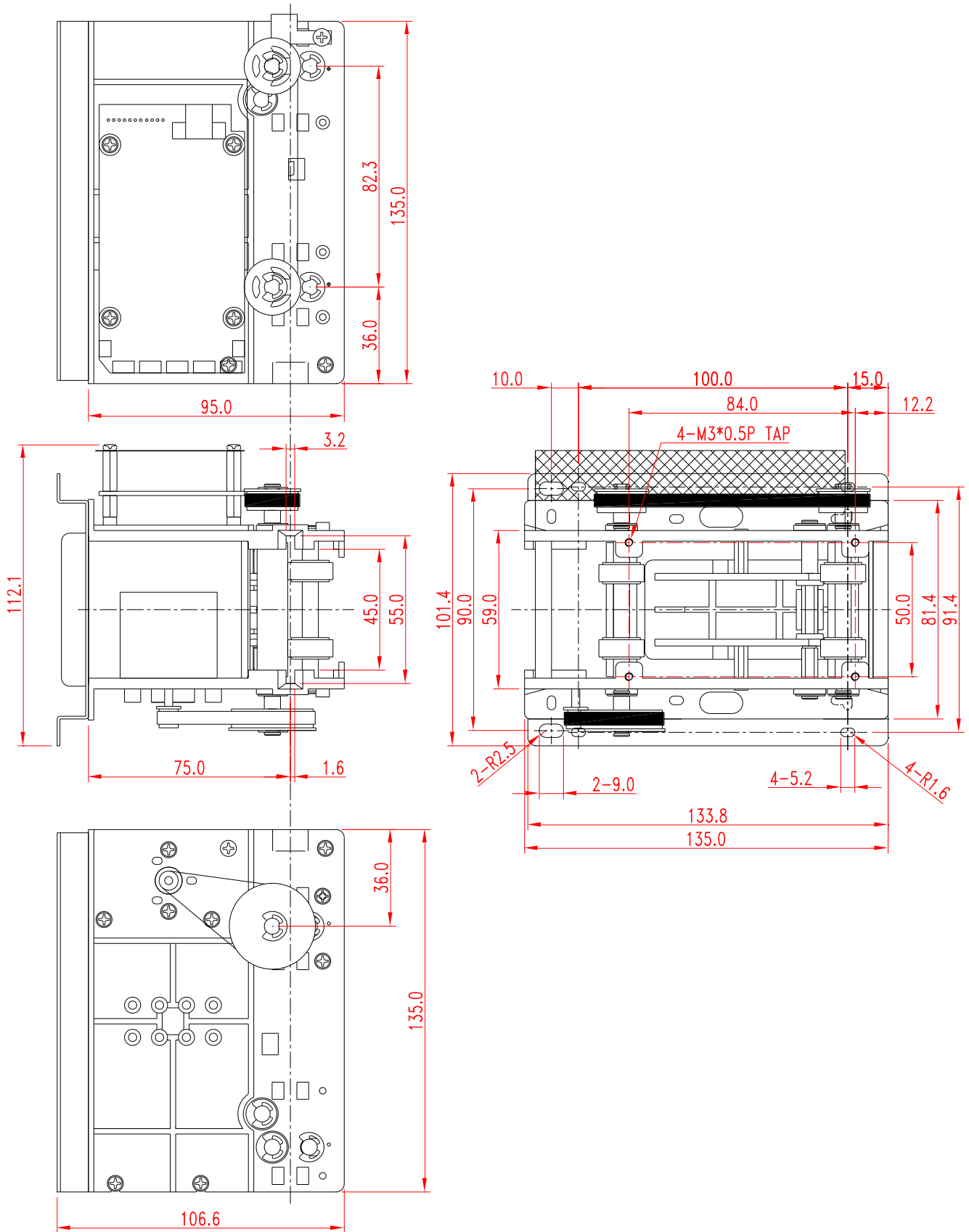

Doc No	KYX-1000 SPECIFICATION	REV	PAGE	DATE
		K	12 OF 24	2013. 07. 26.

MODEL – KYX-1001 , KYT-1002

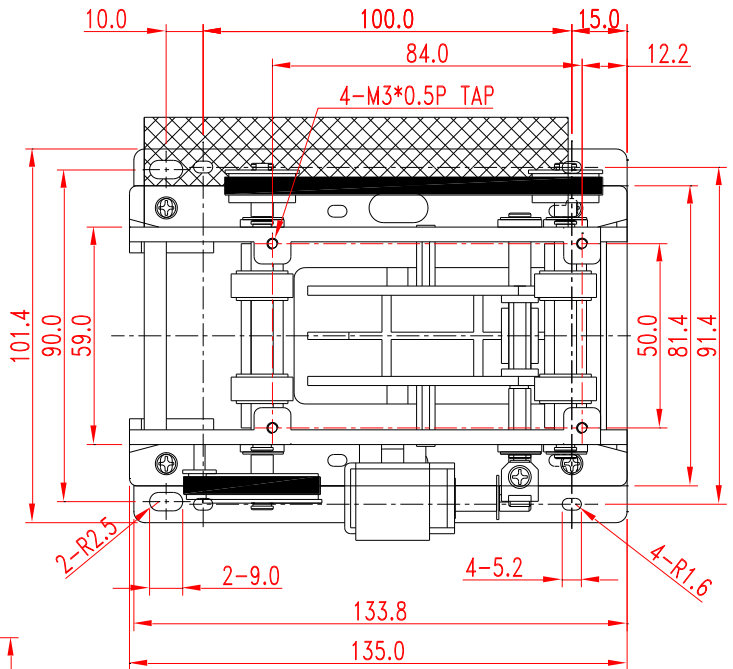
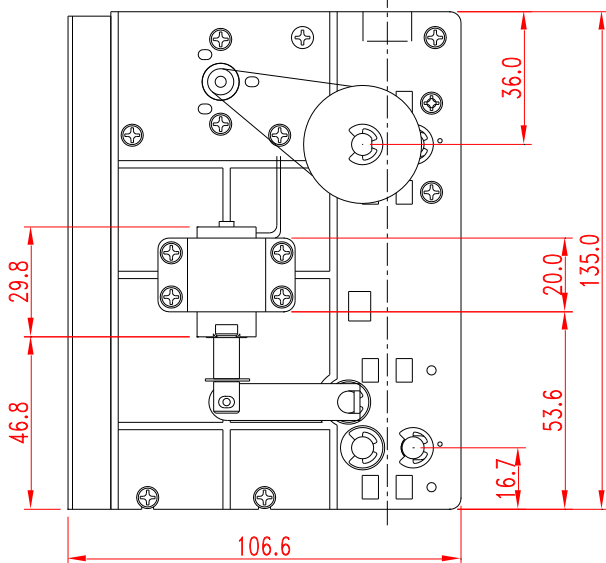
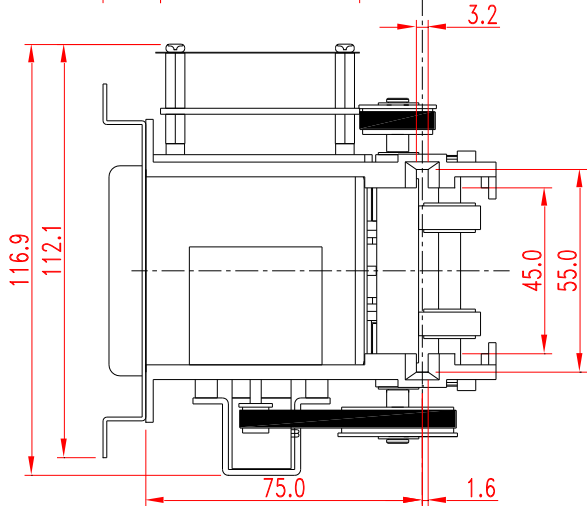
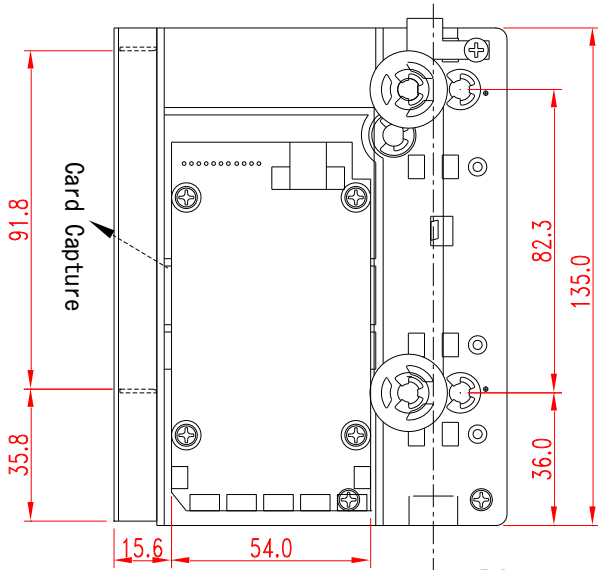

Doc No	KYX-1000 SPECIFICATION	REV	PAGE	DATE
		K	13 OF 24	2013. 07. 26.

MODEL – KYX-1010

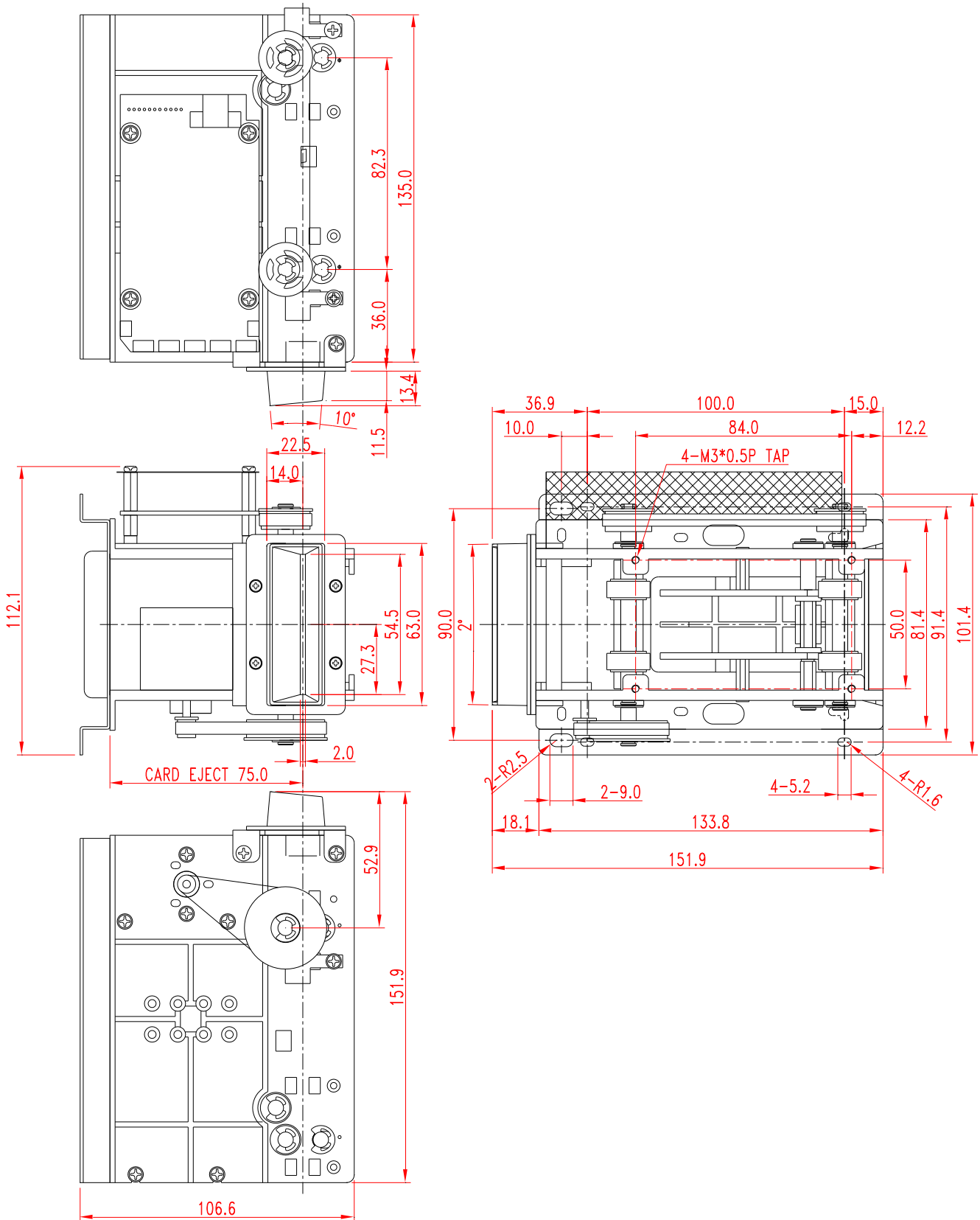

Doc No	KYX-1000 SPECIFICATION	REV	PAGE	DATE
		K	14 OF 24	2013. 07. 26.

MODEL – KYX-1011

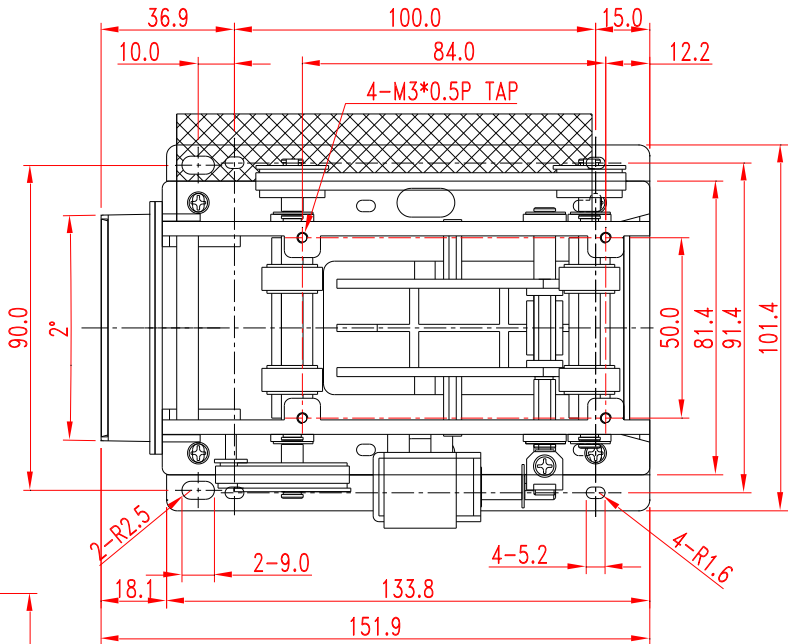
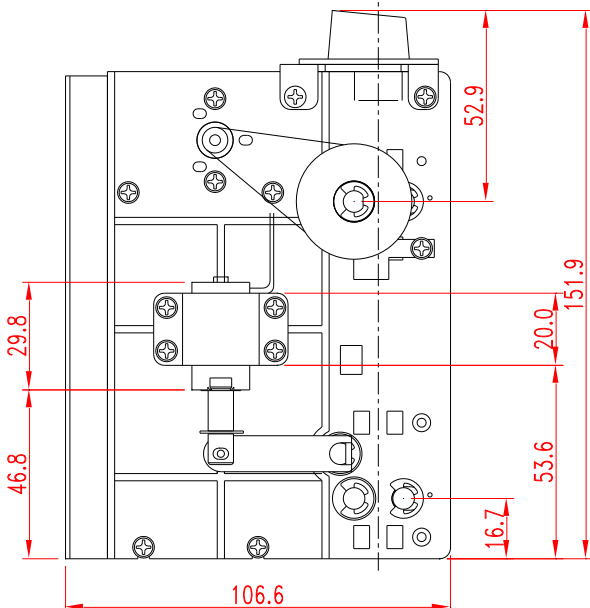
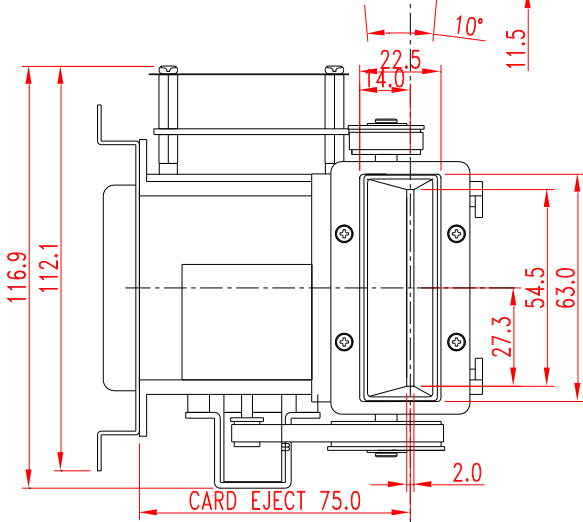
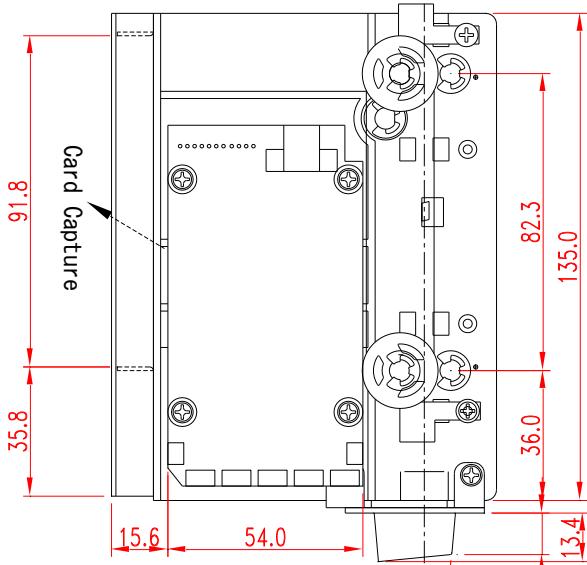

Doc No	KYX-1000 SPECIFICATION	REV	PAGE	DATE
		K	15 OF 24	2013. 07. 26.

MODEL – KYX-1012

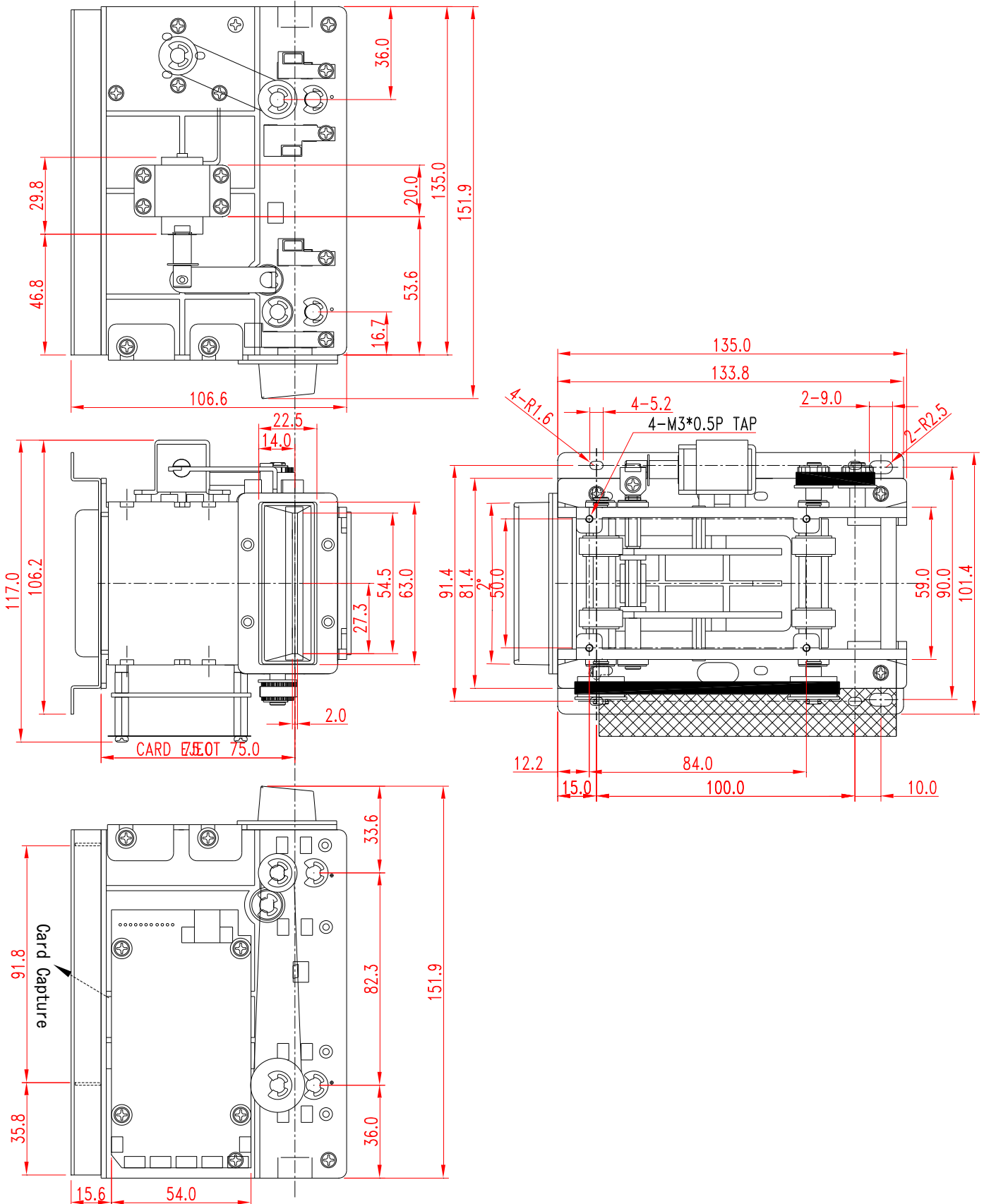

Doc No	KYX-1000 SPECIFICATION	REV	PAGE	DATE
		K	16 OF 24	2013. 07. 26.

MODEL – KYX-1020

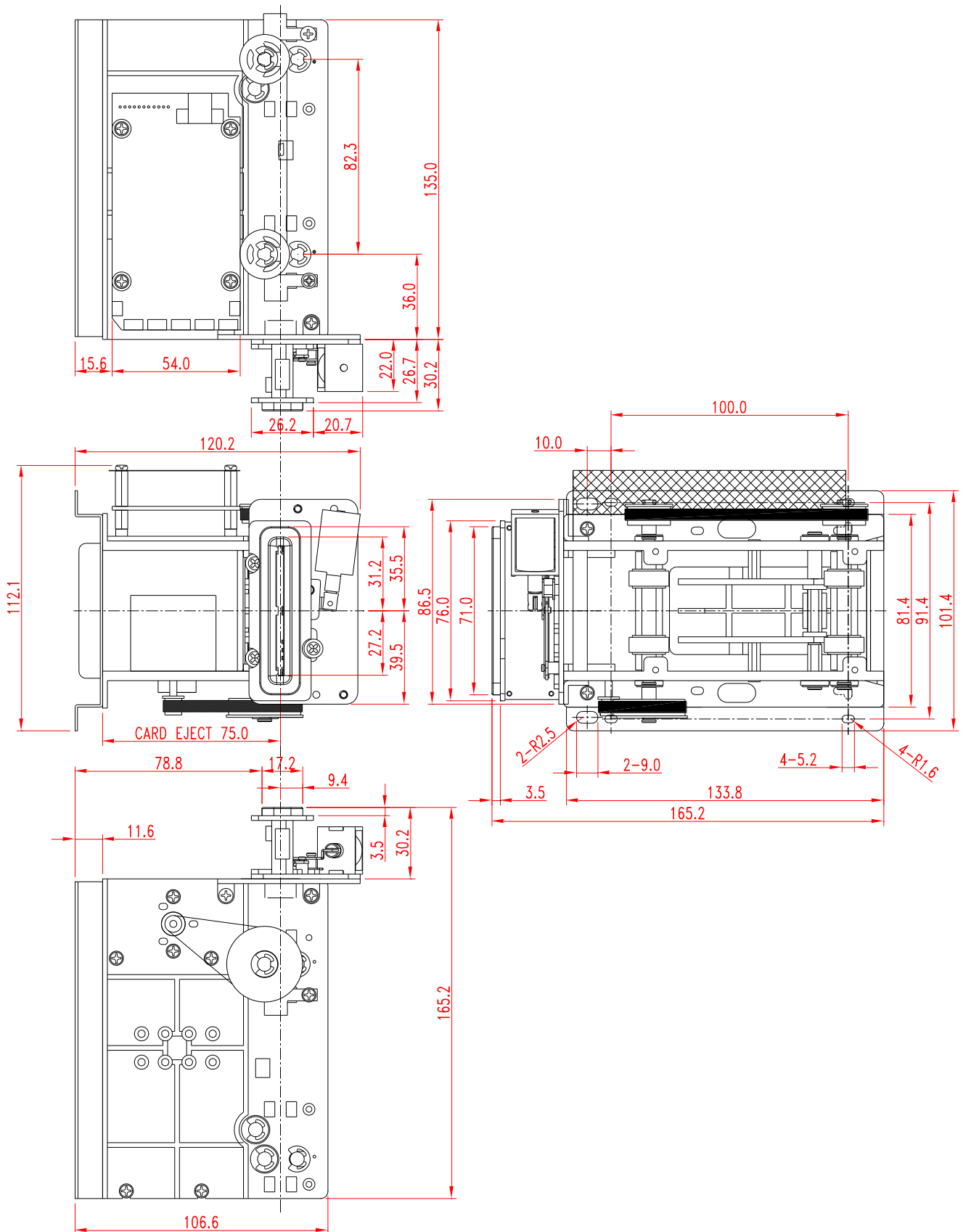

Doc No	KYX-1000 SPECIFICATION	REV	PAGE	DATE
		K	17 OF 24	2013. 07. 26.

MODEL – KYX-1021

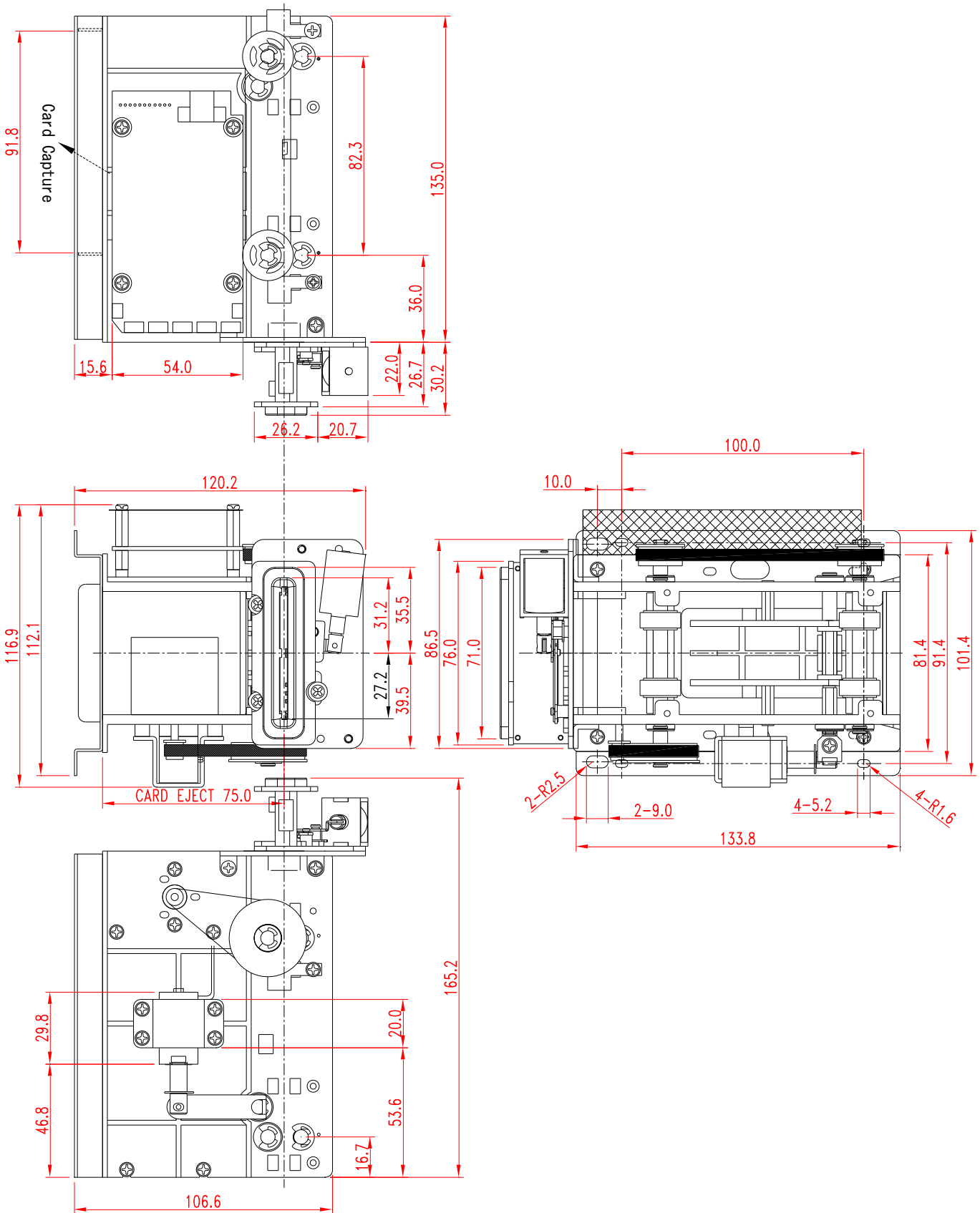

Doc No	KYX-1000 SPECIFICATION	REV	PAGE	DATE
		K	18 OF 24	2013. 07. 26.

MODEL – KYX-1022

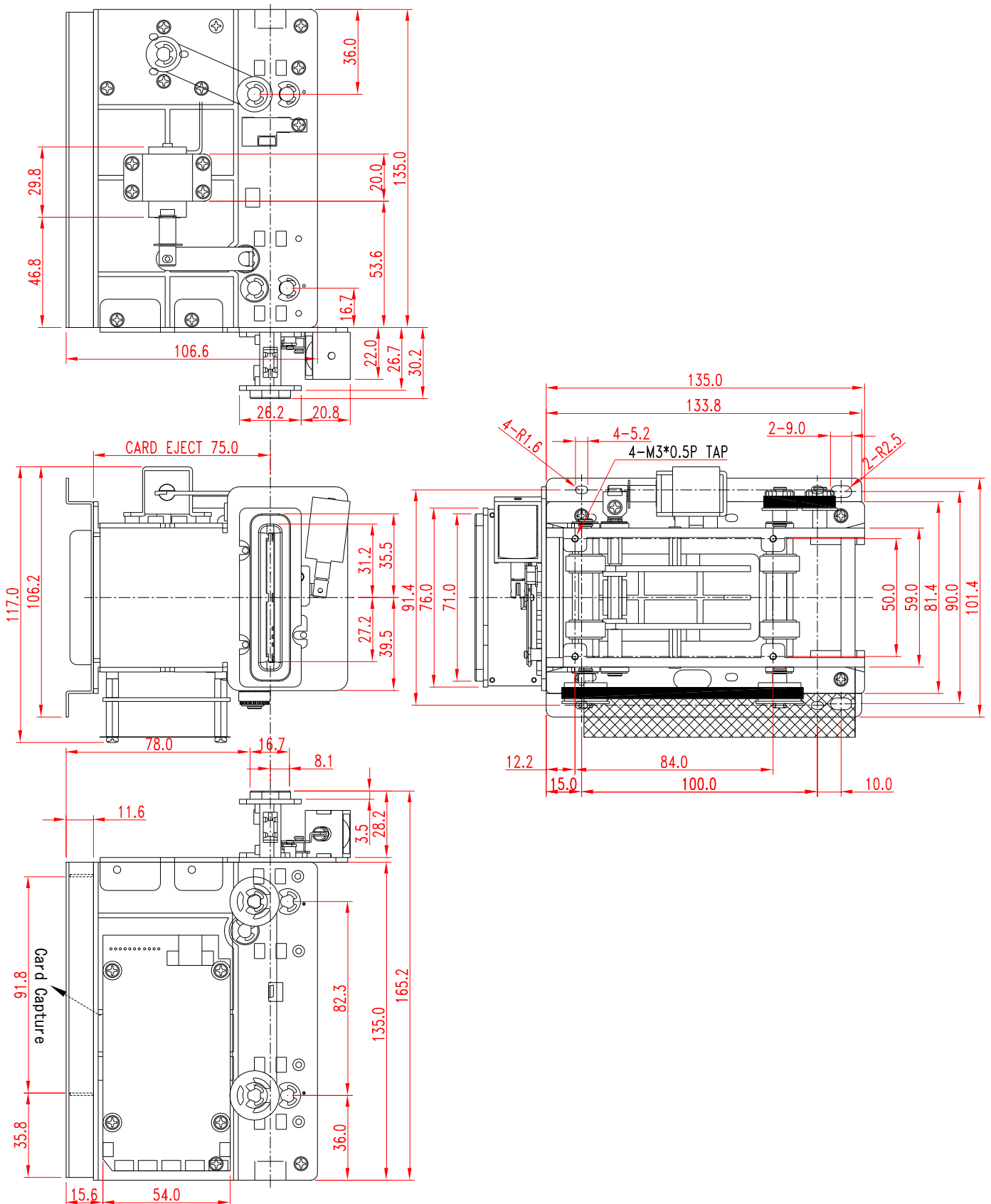

Doc No	KYX-1000 SPECIFICATION	REV	PAGE	DATE
		K	19 OF 24	2013. 07. 26.

MODEL – KYX-1023

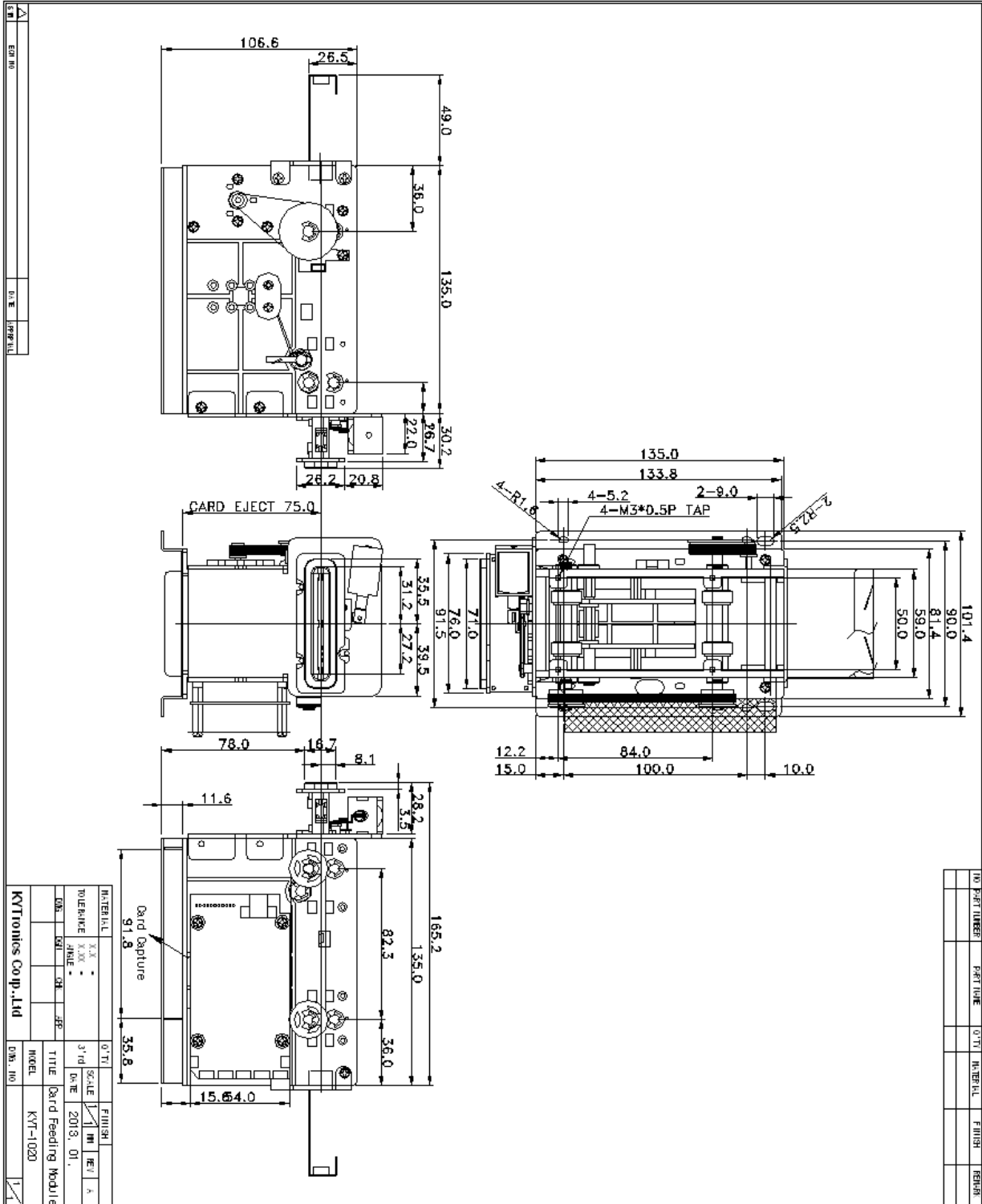

Doc No	KYX-1000 SPECIFICATION	REV	PAGE	DATE
		K	20 OF 24	2013. 07. 26.

6. RS232C Interface

6.1. Control Characters

NANE	Hex Value	Description
STX	02	Start of Text
ETX	03	End of Text
EOT	04	End of Transmission
ENQ	05	Enquiry
ACK	06	Positive Acknowledge
NAK	15	Negative Acknowledge
CAN	18	Cancel

6.2. Frame Format

1. Command structure

STX	Command	ETX	BCC
-----	---------	-----	-----

2. Response structure

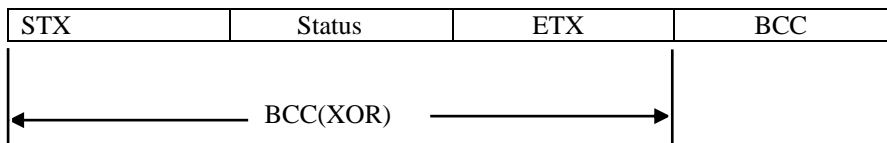

6.3. Communication Protocol Sequence

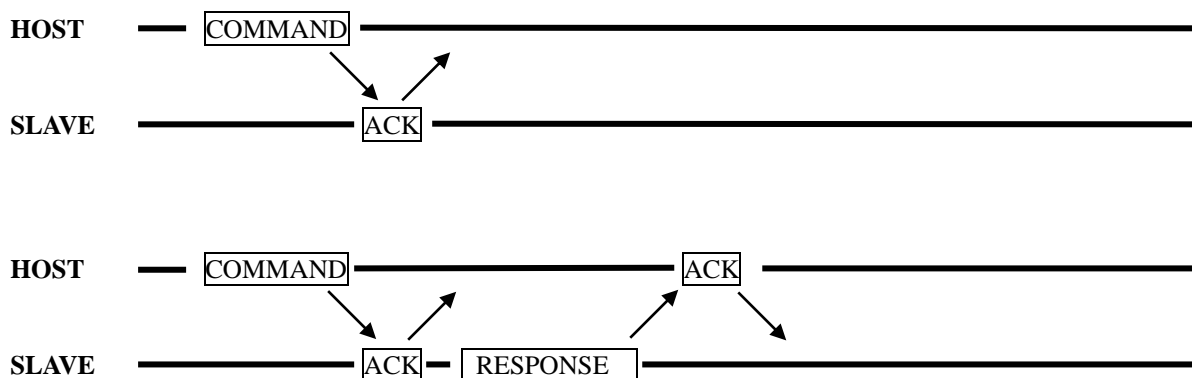

Doc No	KYX-1000 SPECIFICATION	REV	PAGE	DATE
		K	21 OF 24	2013. 07. 26.

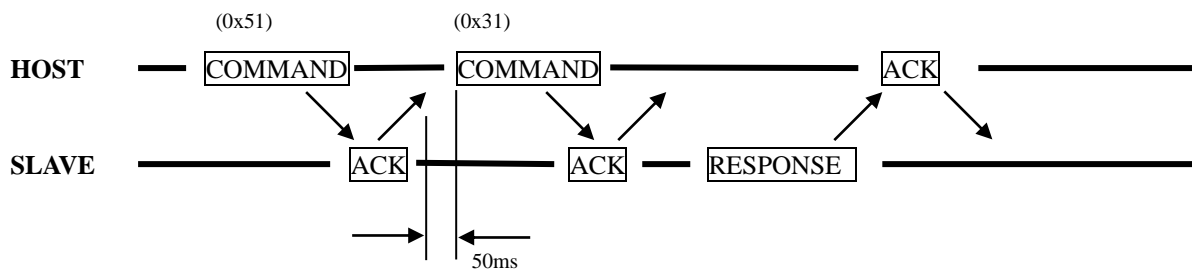
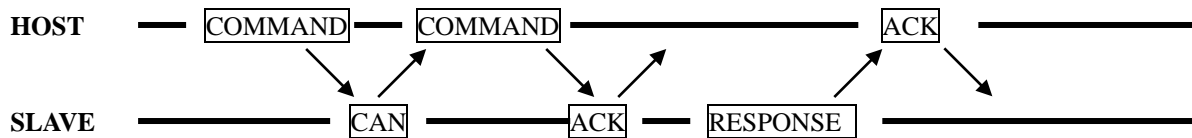
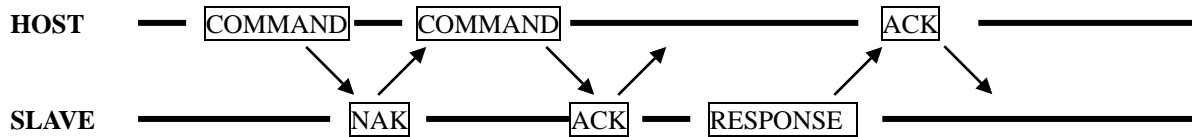
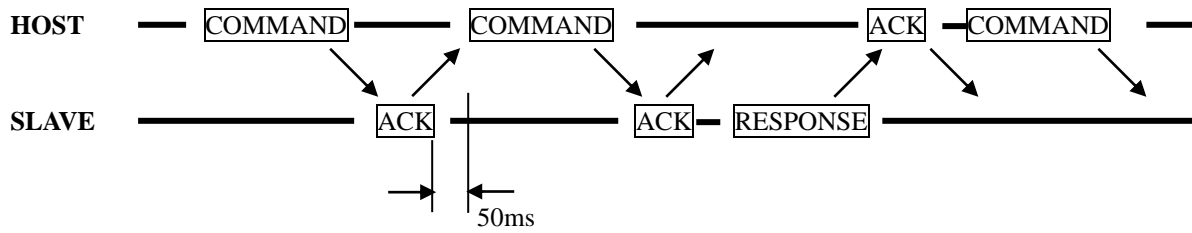

cf) To change Baud Rate , send command 50mS after receiving ACK .

6.4. Command Sets List

	Command	Description	Note
Clear	0x30	Error Clear	
Request	0x31	Status Request	
Move	0x40	Feed In	
	0x41	Feed Out(drop)	
	0x42	Feed Stop	
	0x43	Capture	
	0x44	Feed Stand By	
	0x4B	Feed Out(hold)	
Baud Rate Set	0x50	9600 BPS	
	0x51	19200 BPS	

Doc No	KYX-1000 SPECIFICATION	REV	PAGE	DATE
		K	22 OF 24	2013. 07. 26.

6.5. Command Details

6.5.1. Clear(Command : 0x30)

: Initializing Parameters(Initializing Error Bit)

Command Packet

STX	Command	ETX	BCC
-----	---------	-----	-----

6.5.2. Status Request(Command : 0x31)

: Host's Request for status of dispenser

Command Packet

STX	Command	ETX	BCC
-----	---------	-----	-----

Response Packet

STX	Status	ETX	BCC
-----	--------	-----	-----

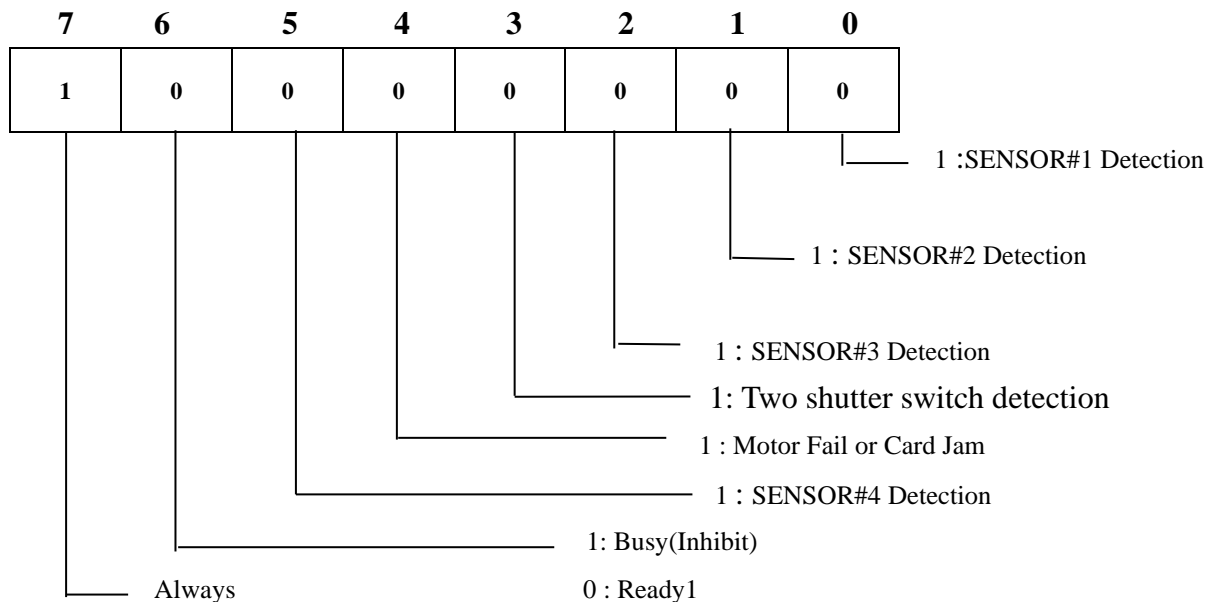

6.5.3. Feed In(Command : 0x40)

: Move the Card from SENSOR#1 to SENSOR#3.

(In Case of KYX-1xx2: Move the Card from SENSOR#3 to SENSOR#1.)

Command Packet

STX	Command	ETX	BCC
-----	---------	-----	-----

Ref) If the sensor not detect the card, above command is immediately terminated.

6.5.4. Feed Out – drop (Command : 0x41)

Doc No	KYX-1000 SPECIFICATION	REV	PAGE	DATE
		K	23 OF 24	2013. 07. 26.

: Move the Card from SENSOR#3 to SENSOR#1.

(In Case of KYX-1xx2: Move the Card from SENSOR#1 to SENSOR#3.)

Command Packet

STX	Command	ETX	BCC
-----	---------	-----	-----

Ref) If the sensor does not detect the card, above command is immediately terminated.

6.5.5. Feed Stop(Command : 0x42)

: Stop the card at the specified location while moving the card

Command Packet

STX	Command	ETX	BCC
-----	---------	-----	-----

6.5.6. Capture (Command : 0x43)

: The card is captured to the error box

Command Packet

STX	Command	ETX	BCC
-----	---------	-----	-----

6.5.7. Feed Stand By (Command : 0x44)

: Move the card to antenna area.

Command Packet

STX	Command	ETX	BCC
-----	---------	-----	-----

6.5.8. Feed Out- hold (Command : 0x4B)

: Move the Card from SENSOR#3 to SENSOR#1. And stop the card when passed by SENSOR#2

(In Case of KYX-1xx2: Move the Card from SENSOR#1 to SENSOR#3. And stop the card when passed by SENSOR#4)

Command Packet

STX	Command	ETX	BCC
-----	---------	-----	-----

Ref) If the sensor does not detect the card, above command is immediately terminated.

Doc No	KYX-1000 SPECIFICATION	REV	PAGE	DATE
		K	24 OF 24	2013. 07. 26.

Example 1) TTL Control Example (SENSOR#1 => SENSOR#3)

